



POWERING INNOVATION THAT DRIVES HUMAN ADVANCEMENT

© 2025 ANSYS, Inc. or its affiliated companies
Unauthorized use, distribution, or duplication is prohibited.

Getting Started with Maxwell®: A 2D Magnetostatic Solenoid Problem



ANSYS, Inc.
Southpointe
2600 Ansys Drive
Canonsburg, PA 15317
ansysinfo@ansys.com
<https://www.ansys.com>
(T) 724-746-3304
(F) 724-514-9494

Release 2025 R1
January 2025

ANSYS, Inc. and
ANSYS Europe,
Ltd. are UL
registered ISO
9001:2015
companies.

Copyright and Trademark Information

© 1986-2025 ANSYS, Inc. Unauthorized use, distribution or duplication is prohibited.

ANSYS, Ansys Workbench, AUTODYN, CFX, FLUENT and any and all ANSYS, Inc. brand, product, service and feature names, logos and slogans are registered trademarks or trademarks of ANSYS, Inc. or its subsidiaries located in the United States or other countries. ICFD is a trademark used by ANSYS, Inc. under license. All other brand, product, service and feature names or trademarks are the property of their respective owners. FLEXlm and FLEXnet are trademarks of Flexera Software LLC.

Disclaimer Notice

THIS ANSYS SOFTWARE PRODUCT AND PROGRAM DOCUMENTATION INCLUDE TRADE SECRETS AND ARE CONFIDENTIAL AND PROPRIETARY PRODUCTS OF ANSYS, INC., ITS SUBSIDIARIES, OR LICENSORS. The software products and documentation are furnished by ANSYS, Inc., its subsidiaries, or affiliates under a software license agreement that contains provisions concerning non-disclosure, copying, length and nature of use, compliance with exporting laws, warranties, disclaimers, limitations of liability, and remedies, and other provisions. The software products and documentation may be used, disclosed, transferred, or copied only in accordance with the terms and conditions of that software license agreement.

ANSYS, Inc. and ANSYS Europe, Ltd. are UL registered ISO 9001: 2015 companies.

U.S. Government Rights

For U.S. Government users, except as specifically granted by the ANSYS, Inc. software license agreement, the use, duplication, or disclosure by the United States Government is subject to restrictions stated in the ANSYS, Inc. software license agreement and FAR 12.212 (for non-DOD licenses).

Third-Party Software

See the legal information in the product help files for the complete Legal Notice for Ansys proprietary software and third-party software. If you are unable to access the Legal Notice, please contact ANSYS, Inc.

Conventions Used in this Guide

Please take a moment to review how instructions and other useful information are presented in this documentation.

- Procedures are presented as numbered lists. A single bullet indicates that the procedure has only one step.
- Bold type is used for the following:
 - Keyboard entries that should be typed in their entirety exactly as shown. For example, “**copy file1**” means you must type the word **copy**, then type a space, and then type **file1**.
 - On-screen prompts and messages, names of options and text boxes, and menu commands. Menu commands are often separated by greater than signs (>). For example, “click **Maxwell 2D > Excitations > Assign > Wave Port.**”
 - Labeled keys on the computer keyboard. For example, “Press **Enter**” means to press the key labeled **Enter**.
- Italic type is used for the following:
 - Emphasis
 - Titles of publications
 - Keyboard entries when a name or a variable must be typed in place of the words in italics. For example, “**copy filename**” means you must type the word **copy**, then type a space, and then type the name of the file.
- The plus sign (+) is used between keyboard keys to indicate that you should press the keys at the same time. For example, “Press Shift+F1” means to press the **Shift** key and, while holding it down, press the **F1** key also. You should always depress the modifier key or keys first (for example, Shift, Ctrl, Alt, or Ctrl+Shift), continue to hold it/them down, and then press the last key in the instruction.

Accessing Commands: *Ribbons*, *menu bars*, and *shortcut menus* are three methods that can be used to see what commands are available in the application.

- The *Ribbon* occupies the rectangular area at the top of the application window and contains multiple tabs. Each tab has relevant commands that are organized, grouped, and labeled. An example of a typical user interaction is as follows:

"Click **Draw > Line**"

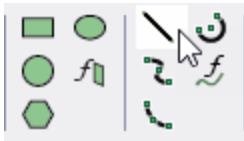

This instruction means that you should click the **Line** command on the **Draw** ribbon tab. An image of the command icon or a partial view of the ribbon is often included with the instruction.

- The *menu bar* (located above the ribbon) is a group of the main commands of an application arranged by category such File, Edit, View, Project, etc. An example of a typical user interaction is as follows:

"On the **File** menu, click the **Open Examples** command" means you can click the **File** menu and then click **Open Examples** to launch the dialog box.

- Another alternative is to use the *shortcut menu* that appears when you click the right-mouse button. An example of a typical user interaction is as follows:

"Right-click and select **Assign Excitation> Wave Port**" means when you click the right-mouse button with an object face selected, you can execute the excitation commands from the shortcut menu (and the corresponding sub-menus).

Getting Help: Ansys Technical Support

For information about Ansys Technical Support, go to the Ansys corporate Support website, <http://www.ansys.com/Support>. You can also contact your Ansys account manager in order to obtain this information.

All Ansys software files are ASCII text and can be sent conveniently by e-mail. When reporting difficulties, it is extremely helpful to include very specific information about what steps were taken or what stages the simulation reached and to include software files as applicable. This allows more rapid and effective debugging.

Help Menu

To access help from the Help menu, click **Help** and select from the menu:

- **[product name] Help** - opens the contents of the help. This help includes the help for the product and its *Getting Started Guides*.
- **[product name] Scripting Help** - opens the contents of the *Scripting Guide*.
- **[product name] Getting Started Guides** - opens a topic that contains links to Getting Started Guides in the help system.

Context-Sensitive Help

To access help from the user interface, press **F1**. The help specific to the active product (design type) opens.

You can press **F1** while the cursor is pointing at a menu command or while a particular window or window tab is open. In this case, the help page associated with the command or open dialog box is displayed automatically.

Table of Contents

Table of Contents	Contents-1
1 - Introduction	1-1
Goals	1-5
2 - Setting Up the Design Environment	2-1
Open and Save a New Project	2-1
Specify a Solution Type	2-2
Set the Drawing Units	2-2
3 - Creating the Geometric Model	3-1
Draw the Plugnut	3-2
Draw the Core	3-3
Keyboard Entry	3-3
Draw the Coil	3-5
Draw the Yoke	3-5
Draw the Bonnet	3-6
Create the Background (Region)	3-7
4 - Setting Up the Solenoid Model	4-1
Assign Materials to Objects	4-1
Access Material Database	4-1
Assign Copper to the Coil	4-2
Assign Cold Rolled Steel to the Bonnet and Yoke	4-3
Select Objects and Create the Material	4-3
Define the B-H Curve For Cold Rolled Steel	4-4
Add B-H Curve Points for Cold Rolled Steel	4-5
Assign ColdRolledSteel to the Yoke and Bonnet	4-6
Assign Neo35 to the Core	4-7
Select the Object and Create the Material	4-7

Select Independent Material Properties	4-7
Manually Enter Material Properties	4-9
Assign Neo35 to the Core	4-9
Create a Relative Coordinate System for the Magnet Orientation	4-9
Complete the Alignment of the Magnet	4-10
Create SS430 Material and Assign to Plugnut	4-11
Select Objects and Create Material	4-11
Define the B-H Curve for SS430	4-11
Assign SS430 to the Plugnut	4-12
Accept Default Material for Background	4-13
Set Up Boundaries and Current Sources	4-13
Types of Boundary Conditions and Sources	4-14
Set Source Current on the Coil	4-14
Assign Balloon Boundary to the Background	4-15
Set Up Force Computation	4-17
Set Up Inductance Computation	4-17
5 - Generating a Solution	5-1
Add Solution Setup	5-1
Adaptive Analysis	5-2
Parameters	5-3
Solver Residual	5-3
Validate Design	5-4
Start the Solution	5-4
Monitoring the Solution	5-5
Viewing Convergence Data	5-7
Solution Criteria	5-7
Completed Solutions	5-8
Plotting Convergence Data	5-8

Viewing Statistics	5-9
6 - Analyzing the Solution	6-1
View Force Solution	6-1
Plot the Magnetic Field	6-2
7 - Adding Variables to the Solenoid Model	7-1
Adding Geometric Variables	7-2
Add a Variable to the Core Object	7-2
Set the Coil Current to a Variable	7-4
Set Variable Ranges for Parametric Analysis	7-4
Redefining Zero Current Sources	7-7
8 - Generating a Parametric Solution	8-1
Model Verification	8-1
Solving the Nominal Problem	8-2
Solving the Parametric Problem	8-2
Monitoring the Solution	8-3
Viewing Parametric Solution Data	8-3
Viewing Parametric Convergence Data	8-4
Plotting Parametric Convergence Data	8-5
Viewing Parametric Solver Profile	8-7
9 - Plotting Results from a Design Variation	9-1
Plotting Fields of a Design Variation	9-3
Apply Solved Variation	9-3
Plot Fields for the Variation	9-4
Animate the Field Plot Across Variations	9-6
10 - Exit the Electronics Desktop	10-1
Index	Index-1

1 - Introduction

Ansys Maxwell is an interactive software package that uses finite element analysis (FEA) to simulate (solve) electromagnetic field problems. Maxwell integrates with other Ansys software packages to perform complex tasks while remaining simple to use. Maxwell incorporates both a set of 2D solvers and 3D solvers in an integrated user interface. This guide will focus on 2D capabilities.

To analyze a problem, you specify the appropriate geometry, material properties, and excitations for a device or system of devices. The Maxwell software then does the following:

- Automatically creates the required finite element mesh.
- Calculates the desired electric or magnetic field solution and special quantities of interest, such as force, torque, inductance, capacitance, or power loss. The specific types of field solutions and quantities that can be computed depend on which Maxwell 2D solution type you specified (electric fields, DC magnetics, AC magnetics, transient fields and data).
- Allows you to analyze, manipulate, and display field solutions.

A sample geometry created with Maxwell appears below:

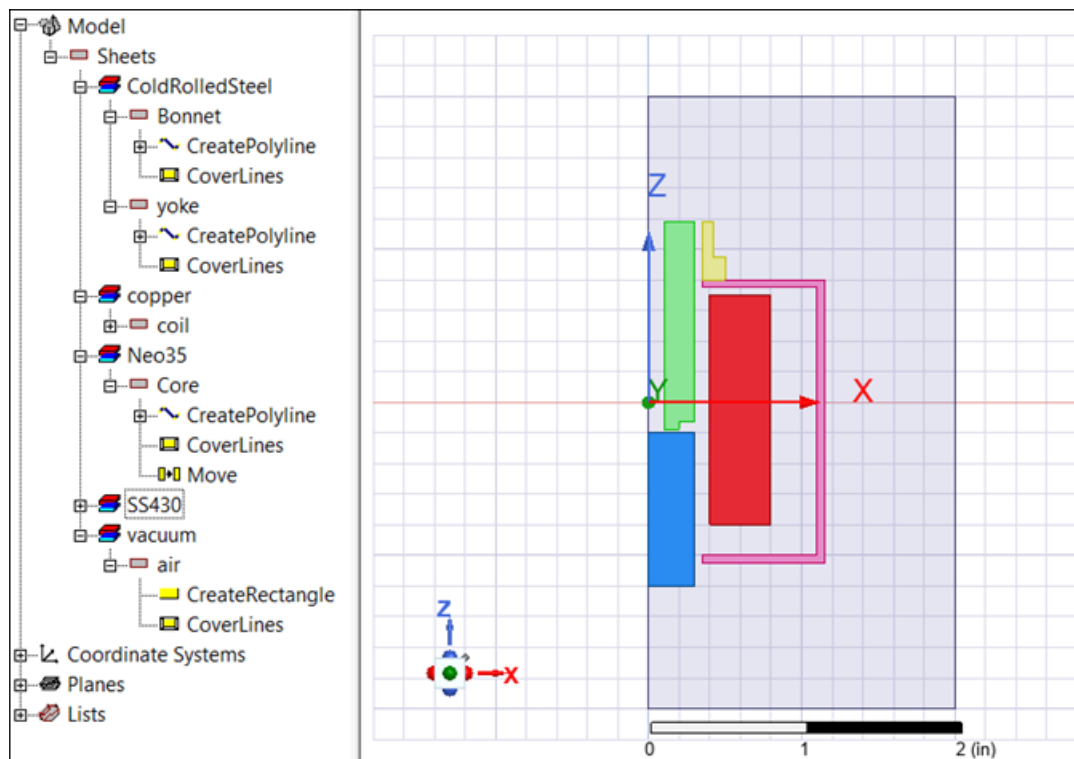

This model is actually a three-dimensional (3D) object. Maxwell 2D analyzes the 2D geometry as a cross-section of the model, then generates a solution for that cross-section.

In addition to XY models, Maxwell 2D can take advantage of 3D geometry that exhibits rotational symmetry about an axis to compute fields in an axisymmetric model. The geometry described in this guide exhibits such symmetry.

The following figure shows the finite element mesh that was automatically generated for the 2D geometry.

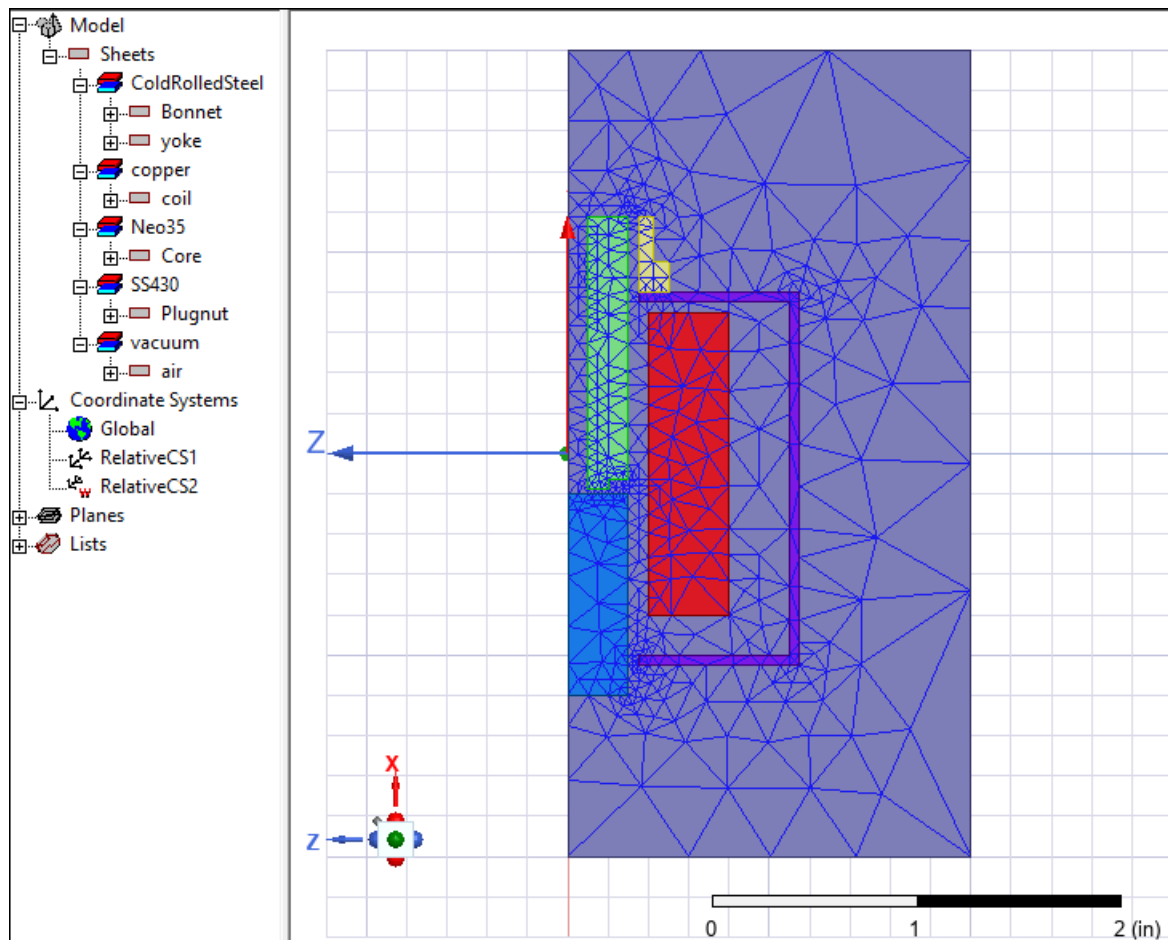

Dividing a structure into many smaller regions (finite elements) allows the system to compute the field solution separately in each element. The smaller the elements, the more accurate the final solution.

The Sample Problem

The sample problem, shown below, is a solenoid that consists of the following objects:

- Core
- Bonnet
- Coil
- Yoke
- Plugnut

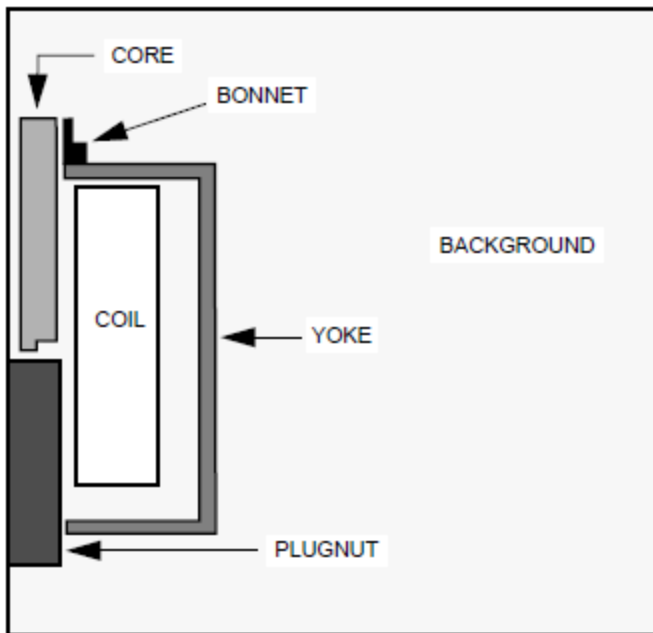

The 2D diagram actually represents a 3D structure that has been revolved around an axis of symmetry, as shown in the figure below. In this figure, part of the 3D model has been cut away so that you can see the interior of the solenoid.

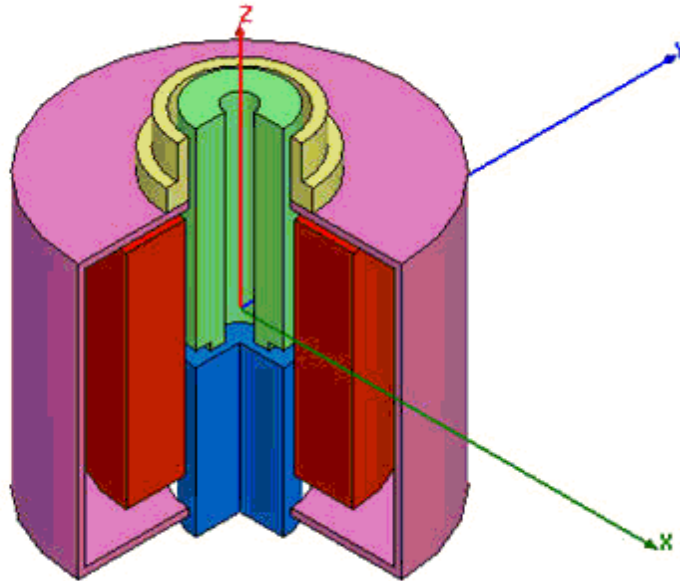

Because the cross-section of the solenoid is constant, it can be modeled as an axisymmetric model in Maxwell 2D. Material properties, excitations, and boundary conditions must also be appropriately modeled by an axisymmetric design.

Goals

Your goals in *Getting Started with Maxwell: A 2D Magnetostatic Solenoid Problem* are as follows:

- Determine the force on the core due to the source current in the coil
- Determine whether any of the nonlinear materials reach their saturation point

You will accomplish these goals by doing the following:

1. Draw the plugnut, core, coil, yoke, and bonnet using the **Modeling** commands.
2. Define and assign materials to each object.
3. Define boundary conditions and current sources required for the solution.
4. Request that the force on the core be computed using the **Parameters** section of the project tree.
5. Specify solution criteria and generating a solution using the **Add Solution Setup** and **Analyze** commands. You will compute both a magnetostatic field solution and the force on the core.
6. View the results of the force computation.
7. Plot saturation levels and contours of equal magnetic potential via the **Post Processor**.

This simple problem illustrates the most commonly used features of Maxwell 2D.

2 - Setting Up the Design Environment

In this chapter you will complete the following tasks:

- Open and save a new project.
- Insert a new Maxwell design into the project.
- Select a solution type for the project.
- Set the drawing units for the design.

Open and Save a New Project

A project is a collection of one or more designs that is saved in a single *.aedt file. A new project is automatically created when Ansys Electronics Desktop is launched.

To create a new project:

1. Double-click the **Ansys Electronics Desktop** icon on your desktop to launch Ansys Electronics Desktop.
 - You can also start Ansys Electronics Desktop by clicking **Start > All Programs > Ansys EM Suite [version] > Ansys Electronics Desktop [version]** from the Windows Start menu.

2. Click **Project > Insert Maxwell 2D Design**.

The new design is listed in the Project Manager tree. By default, it is named **Maxwell2DDesign1**. The **Modeler** window appears to the right of the Project Manager window.

3. Click **File > Save As**.

The **Save As** dialog box appears.

4. Locate and select the folder in which you want to save the project.
5. Type **Solenoid** in the **File name** box, and click **Save**.
6. The project is saved in the specified folder under the name **Solenoid.aedt**. Rename the design:
 - a. Right-click **Maxwell2DDesign1**.
A shortcut menu appears.
 - b. Select **Rename**.
The design name becomes highlighted and editable.
 - c. Type **Solenoid** as the name for the design, and press **Enter**.
The project and design are now both named **Solenoid**.

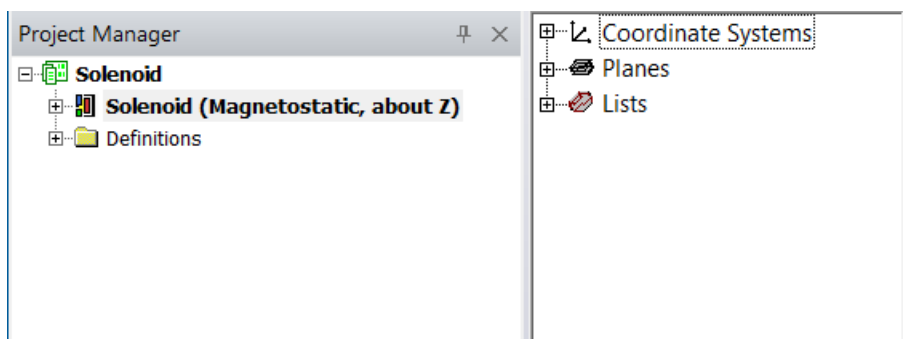

Note: The solution type and axis will be selected in a later step.

Specify a Solution Type

As mentioned in the introduction, multiple solution types are available, depending on the specific application. For this design, choose a **Magnetostatic** solution.

1. Click **Maxwell 2D > Solution Type** from the menus.
The **Solution Type** dialog box appears.
2. Select the **Magnetostatic** radio button.
3. In the **Geometry Mode** drop-down menu, select **Cylindrical about Z**.
4. Click **OK**.

Note: Many commands in the **Maxwell 2D** menu are also available by right-clicking on various sections of the Project Manager tree. For example, right-click on **Solenoid (Magnetostatic about Z)** in the Project Manager tree and you can select and change the **Solution Type**.

Set the Drawing Units

1. Click **Modeler > Units**.
The **Set Model Units** dialog box appears.
2. Select **in (inches)** from the **Select units** drop-down menu.
3. Click **OK**.

3 - Creating the Geometric Model

In this chapter you will complete the following tasks:

- Use the rectangle drawing mode to create a solenoid plugnut.
- Create the solenoid's core, yoke, and bonnet objects using the polyline command.
- Explore the use of keyboard entry mode in creating the coil, yoke and bonnet objects.
- Create the solenoid coil.
- Create the background object.

Create the Geometry

The solenoid model used in this example is made up of five objects: a plugnut, core, coil, yoke, and bonnet. All objects are created using the **Draw** commands as described in the following sections.

The dimensions of the solenoid are shown below. For axisymmetric structures, the axis of symmetry is the Z-axis, and drawing is performed in the XZ plane with all objects in the $X > 0$ portion of the plane. You will use these dimensions, which are given in inches, to create the geometric model.

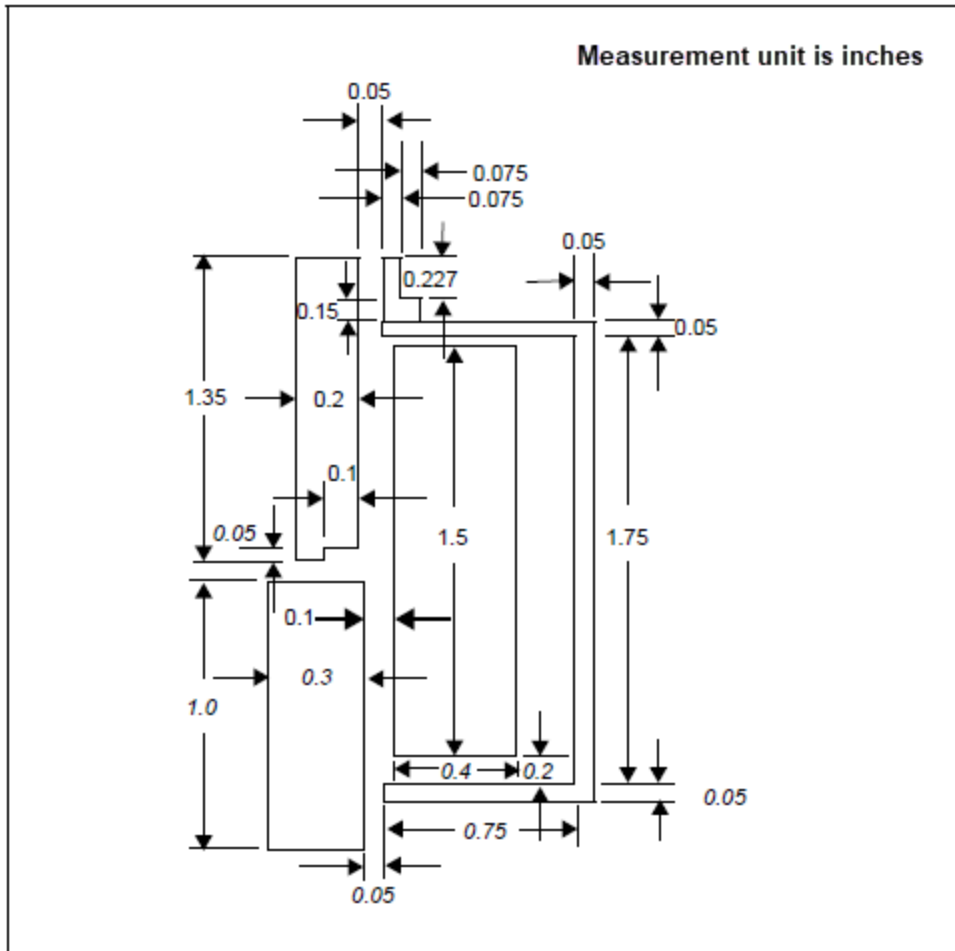

The following pages step you through drawing this model.

Draw the Plugnut

First, draw the plugnut using the rectangle command.

To create the plugnut:

1. Click **Draw > Rectangle**.

The cursor changes to a small black box, indicating that you are in **Drawing** mode.

2. Select one corner of the rectangle by clicking at the **(0,0,-0.2)** location, and press the **Tab** key to jump to the manual entry area in the Status Bar at the bottom of the screen.
3. Notice the Status Bar is prompting for the Opposite corner of the Rectangle. Type **0.3** in the **dX** box, ensure that **dY** is set to **zero**, and type **-1.0** in the **dZ** box. Press **Enter** to complete the creation of the rectangle.

The default properties appear in the **Properties** window.

Note: The Properties window can be used to configure options for the selected object.

4. In the Properties window's **Attribute** tab, change the **Name** (currently **Rectangle1**) to **Plugnut** by clicking on **Rectangle1**. The field becomes editable and you can enter **Plugnut** as the new object name.
5. Optionally, change the color of the rectangle to **blue**:
 - a. In the **Color** row, click the **Edit** button.
The **Color** palette dialog box appears.
 - b. Select any of the blue shades from the **Basic colors** group, and click **OK** to return to the **Properties** window. The object color change will not be apparent while it is currently selected.
6. Optionally, in the history tree, expand **Model > Solids > Plugnut**, and double-click the **CreateRectangle** entry to display the **Command** tab in the Properties window. It can be used to view and edit the geometric data. For this example, we do not need to edit the geometric data.
7. Optionally, when using the pop-up **Properties** dialog box, click **OK** to close the **Properties** window. A rectangle named **Plugnut** is now part of the model.

Draw the Core

Next, use the polyline command to create the core. Instead of selecting coordinates in the modeler window as you did for the plugnut, you will be using the keyboard entry method to select the line coordinates.

Keyboard Entry

When creating objects in the modeler, you can manually enter coordinates. Manual entry is particularly useful when the dimensions fall between the grid spacing.

In order to manually enter points, click the **Tab** key to move the system focus from the drawing window to the keyboard entry area of the status bar that allows entry of direct vertices or dimensions depending upon the object being created. The status bar also contains prompts to assist with the manual entry process.

Once in manual entry mode, you may continue to press the **Tab** key to switch between the entry fields.

To create the core:

1. Click **Draw > Line**.

The cursor changes to a small black box, indicating that you are in **Drawing** mode.

2. Press the **Tab** key to switch the focus to the keyboard entry area at the bottom of the screen.

Note: Do not move the mouse once the focus has switched to the keyboard entry area or the system will revert back to mouse entry mode and any data that has been manually entered will be lost.

3. Enter the coordinate **(0.1, 0, 1.175)** for the first vertex. Pressing the **Tab** key switches between the fields for easy data entry. Press **Enter** once the coordinate data is entered.

Note: The first vertex may be outside the viewable drawing area. If so, hold down the **Shift** key and move the mouse slightly. The mode will switch to **Pan** mode. While continuing to hold the **Shift** key down, press and hold the left mouse button. Drag the mouse to pan the modeler window and make more of the positive **Z-axis** available. Releasing the mouse button and shift key exits **Pan** mode automatically.

4. The Status Bar now prompts for the next point on the line. Using the **Tab** key to switch between fields, enter the values for the second point: **(0.1,0,-0.175)**. Press **Enter**.
5. Continue creating the core object by entering each of the points in the table in succession.

Table 1:

X	Y	Z
0.2	0	-0.175
0.2	0	-0.125
0.3	0	-0.125
0.3	0	1.175
0.1	0	1.175

6. Press **Enter** twice for the final vertex.
An object named polyline1 is created, and the **Properties** window contains the default information for the newly created object.

Note: Pressing **Enter** twice after entering the final vertex causes the modeler to end the polyline creation process. Because the polyline creates a closed polygon, a 2D sheet object is automatically created from the series of vertices.

7. Click the **Attribute** tab.
8. Change the **Name** to **Core**.
9. Optionally change the color of the **Core** object to **green**.

Draw the Coil

Now draw the coil object using the keyboard entry technique discussed in the previous section.

To create the coil:

1. Click **Draw > Rectangle**.

The cursor changes to a small black box, indicating that you are in **Drawing** mode.

2. Press the **Tab** key to switch the focus to the keyboard entry area at the bottom of the screen.
3. Enter the coordinate **(0.4, 0, 0.7)** for the rectangle position. Pressing the **Tab** key switches between the fields for easy data entry. Press **Enter** once the coordinate data is entered.
4. The Status Bar now prompts for the opposite corner of the rectangle. Using the **Tab** key to switch between fields, enter the values for the dimensions of the coil. Type **0.4** for **dX**, **0** for **dY**, and **-1.5** for **dZ**. Press **Enter** to complete the creation of the rectangle.

Note: You may enter the exact location of the opposite corner of the rectangle by switching the entry mode from relative to absolute using the drop-down list box.

5. In the Properties window's **Attribute** tab, change the **Name** (currently **Rectangle1**) to **Coil**.
6. Optionally, change the color of the rectangle to **Red**.

Draw the Yoke

Next, use the polyline command to create the yoke of the solenoid.

To create the yoke:

1. Click **Draw > Line**.
2. Press the **Tab** key to enter keyboard entry mode.
3. Create the yoke object by entering each data point from the following table followed by the **Enter** key.

Table 2:

X	Y	Z
0.35	0	-1.05
1.15	0	-1.05
1.15	0	0.8
0.35	0	0.8
0.35	0	0.75
1.1	0	0.75

X	Y	Z
1.1	0	-1.0
0.35	0	-1.0
0.35	0	-1.05

4. After Entering the final vertex, press the **Enter** key twice. An object named polyline1 is created. The **Properties** window contains the default information for the newly created object.
5. Click the **Attribute** tab.
6. Change the **Name** to **Yoke**.
7. Optional: Change the color of the **Yoke** object to purple.

Draw the Bonnet

As in the previous section, use the polyline command in keyboard entry mode to create the bonnet of the solenoid.

To create the bonnet:

1. Click **Draw > Line**.
Press the **Tab** key to enter keyboard entry mode.
2. Create the bonnet object by entering each data point from the following table followed by the **Enter** key.

Table 3:

X	Y	Z
0.35	0	0.8
0.5	0	0.8
0.5	0	0.95
0.425	0	0.95
0.425	0	1.177
0.35	0	1.177
0.35	0	0.8

3. After entering the final vertex, press the **Enter** key twice. An object named Polyline1 is created.
4. In the **Properties** window's **Attribute** tab, change the **Name** to **Bonnet**.
5. Optionally change the color of the **Bonnet** object to light yellow.
6. Verify that the geometric model appears as shown in the following graphic:

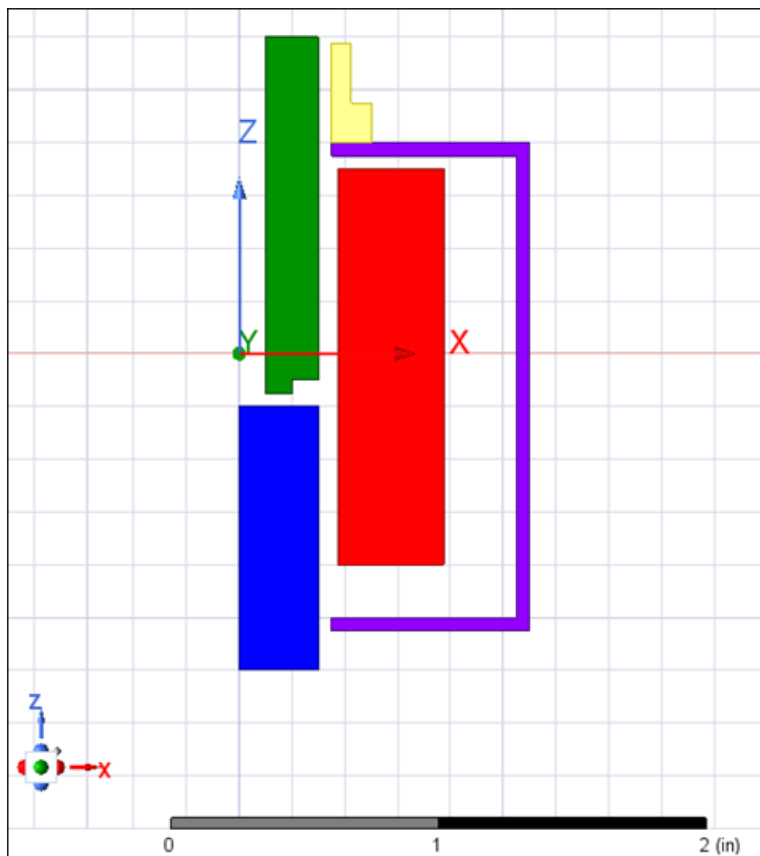

7. Click **File > Save** to save all of the operations up to this point.

Create the Background (Region)

Define a background region box with the origin at (0, 0, -2) and the dimensions of (2, 0, 4).

To create the background region box:

1. Click **Draw > Rectangle**.
2. Type the box position (**0, 0, -2**) in the **X, Y, and Z** fields at the bottom of the screen, and then press **Enter**.
3. Type the box size (**2, 0, 4**) in the **dX, dY, dZ** fields, and then press **Enter**.
4. Click the **Properties** window's **Attribute** tab.
5. Change the **Name** (currently **Rectangle1**) to **Bgnd**.
6. Set the transparency to **0.9**:
 - a. Click the button for the **Transparent** property.

The **Set Transparency** dialog box appears.

- b. Type **0.9** in the text box, and click **OK** to return to the **Properties** window.

Note: Alternatively, the **Draw > Region** command may be used to create the background object.

- 7. The final geometry should look similar to the following:

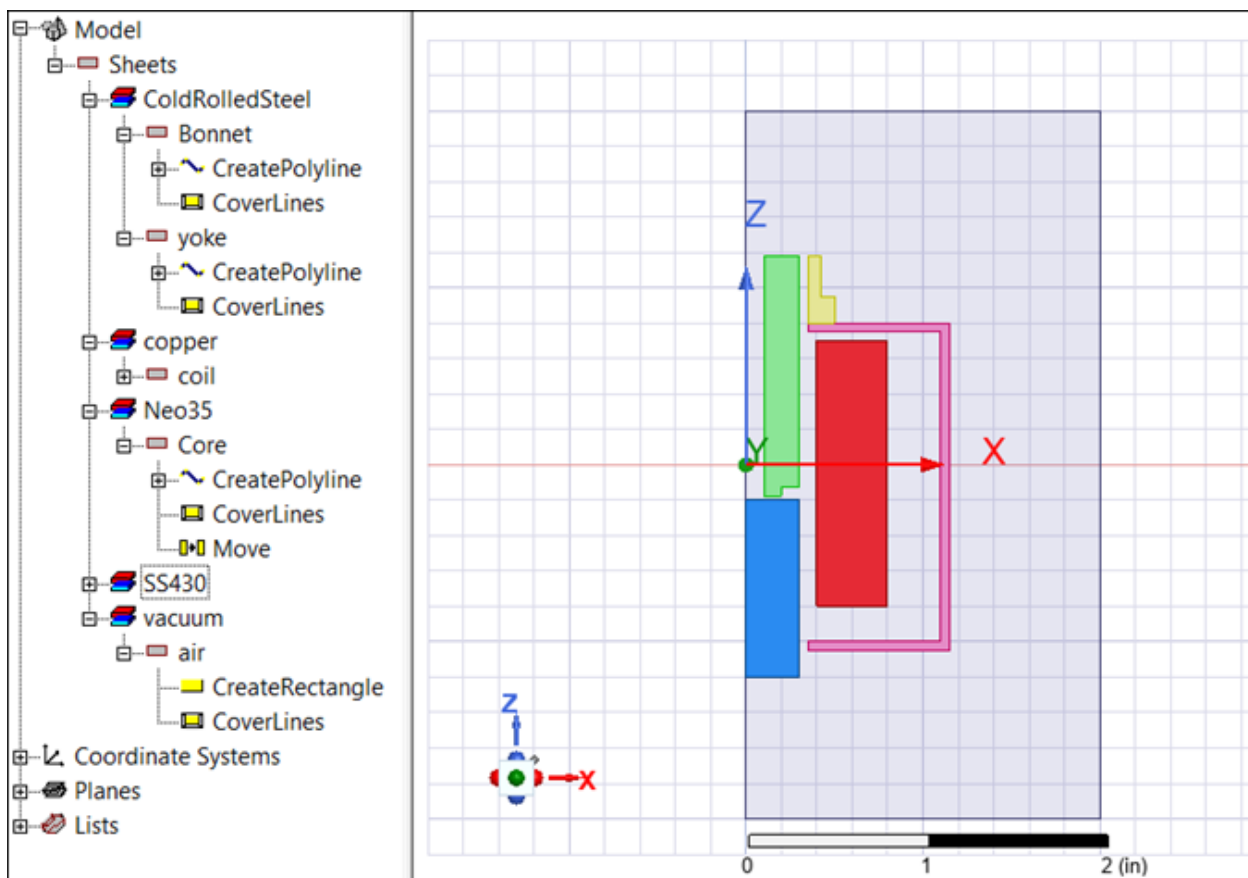

- 8. Click **File > Save** to save the final version of the model before moving on to defining materials.

4 - Setting Up the Solenoid Model

In this chapter you will complete the following tasks:

- Assign materials with the appropriate material attributes to each object in the geometric model.
- Define any boundary conditions and sources that need to be specified, such as the source current of the coil.
- Configure the simulation to calculate the force acting on the core.

Assign Materials to Objects

The next step in setting up the solenoid model is to assign materials to the objects in the model. Materials are assigned to objects via the **Properties** window. You will do the following:

- Assign **copper** to the coil.
- Define the material **ColdRolledSteel** (a nonlinear magnetic material) and assign it to the bonnet and yoke.
- Define the material **Neo35** (a permanent magnet) and assign it to the core.
- Define the material **SS430** (a nonlinear magnetic material) and assign it to the plugnut.
- Accept the default material that is assigned to the background object, which is **vacuum**.

Access Material Database

To access the **Material Database**:

1. Select the coil object by clicking in the **Model Window** or by selecting it in the history tree.
2. Once you have selected the coil, click in the Material Value field of the **Properties Window** and select **Edit**.

The Select Definition dialog appears to allow material definitions to be assigned to the selected object. Before a material is assigned, the Coil is considered a vacuum:

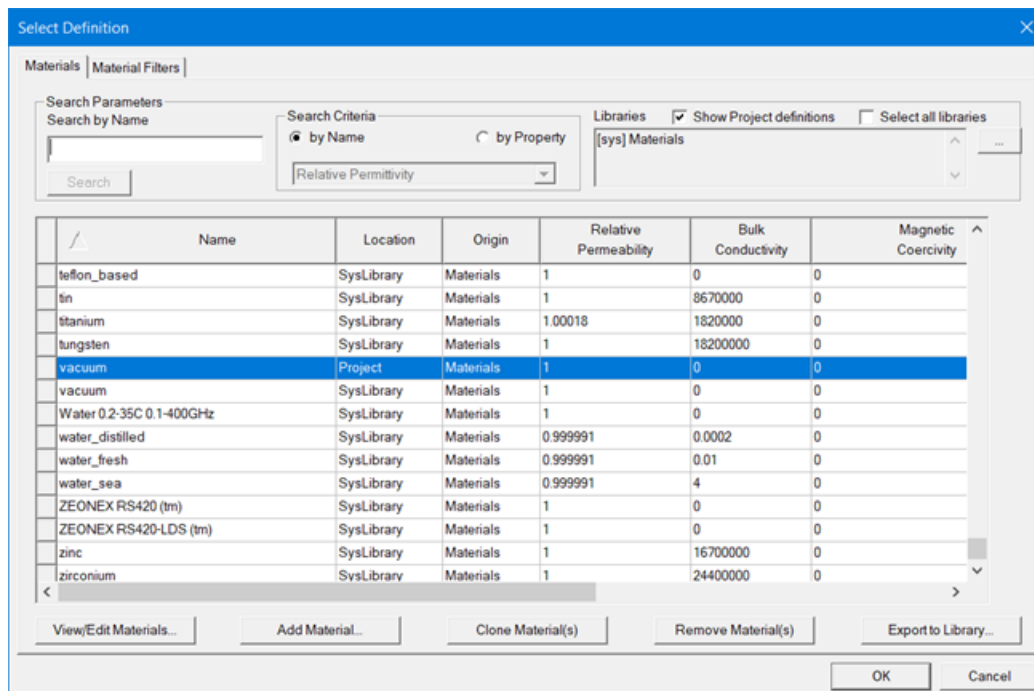

Assign Copper to the Coil

In the actual solenoid, the coil is made of copper. To assign this material to the coil:

1. Scroll the database table to the definition of copper in the Material Manager.
2. Select it by clicking on the name field.
3. Click **OK**.

The **Properties** window will now show copper in the Material Value field for the Coil object, and **Coil** will be listed under copper in the **Object** list.

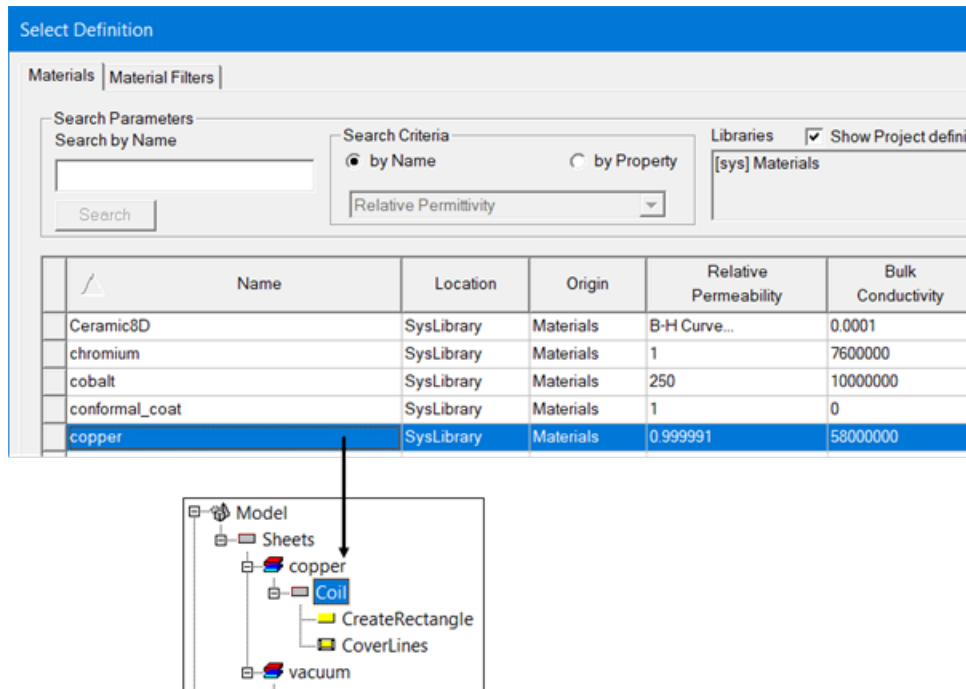

Assign Cold Rolled Steel to the Bonnet and Yoke

The bonnet and yoke of the solenoid are made of cold rolled steel. Because this material is not in the database, you must create a new material, **ColdRolledSteel**. This material is nonlinear — that is, its relative permeability is not constant and must be defined using a **B** vs. **H** curve. Therefore, when you enter the material attributes for cold rolled steel, you will also define a B-H curve.

Select Objects and Create the Material

To select the objects and create the new material:

1. Select both the **Bonnet** and **Yoke** (click on the **Bonnet** and then, while holding the **Ctrl** key down, click on the **Yoke**).
2. Click the **Material Value** field from the **Properties** window and select **Edit** from the drop down menu to open the **Select Definition** window.
3. Select **Add Material**. The **View/Edit Material** window appears.
4. Under **Material Name**, change the name of the new material from **Material1** to **ColdRolledSteel**.
5. Change the **Relative Permeability** type field from **Simple** to **Nonlinear** by clicking in the Type field to access the **Nonlinear** option. The **Rel. Permeability** value field changes to a button labeled **BH Curve**.

Define the B-H Curve For Cold Rolled Steel

To define the properties of cold rolled steel, use the **BH Curve** button to define a B-H curve giving the relationship between **B** and **H** in the material.

To define the B-H curve, click **BH Curve** in the **Relative Permeability value** field. The **B-H Curve Entry** window appears.

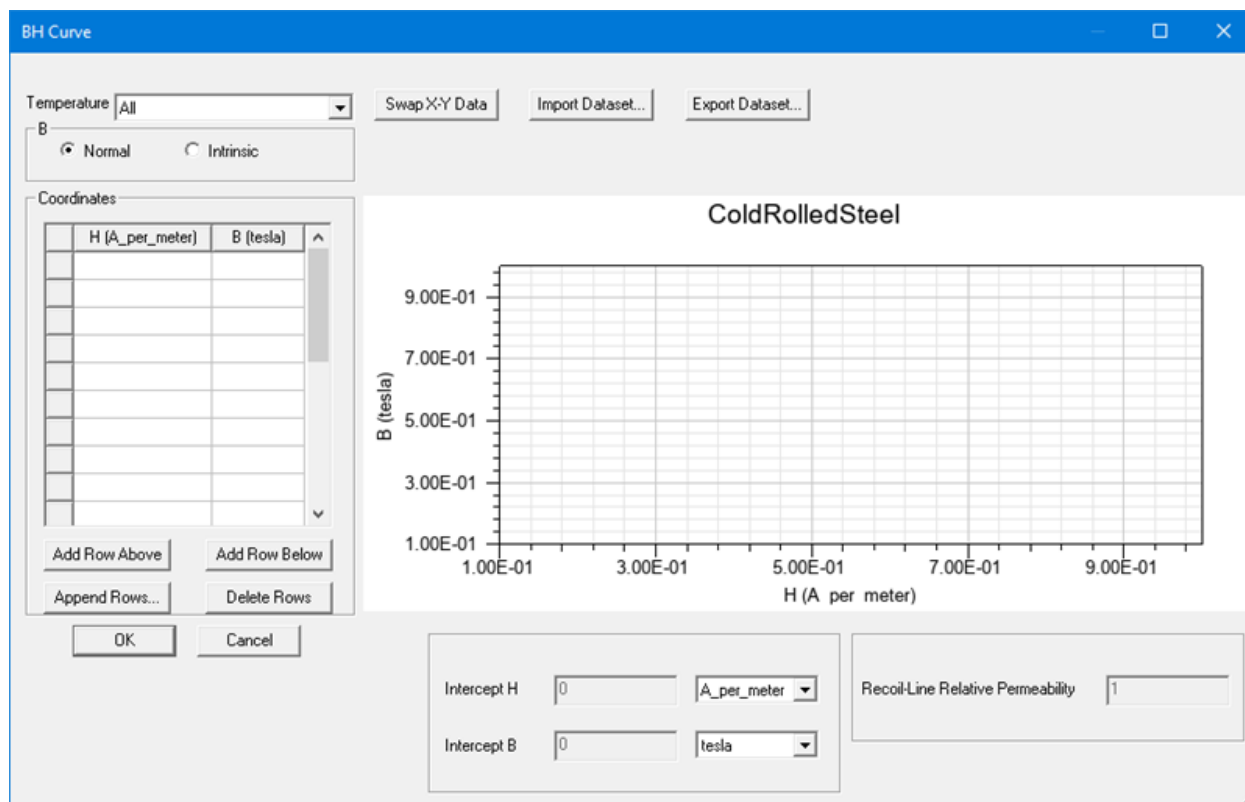

On the left is a blank H,B table where the **H** and **B** values of individual points in the B-H curve are displayed as they are entered. On the right is a graph where the points in the B-H curve are plotted as they are entered.

Note: When defining B-H curves, keep the following in mind:

- A B-H curve may be used in more than one model. To do so, save (export) it to a disk file, which can then be imported into other 2D models.
- Maxwell 3D can read B-H curve files that have been exported from Maxwell, enabling you to use the same curves for both 2D and 3D models. In this guide, you will not be exporting them to files.

Add B-H Curve Points for Cold Rolled Steel

To enter the points in the B-H curve:

1. Click in the table entry area under the H column, row 1.
2. Enter **0.0** for the minimum H value and press the **Tab** key.
3. Enter **0.0** for the minimum B value and press the **Tab** key.
4. Enter the rest of the values for the B-H curve from the following table, using the **Tab** key to accept the entry and move to the next available cell.

Table 4:

H	B
0.0	0.0
1080	0.858
1480	1.06
2090	1.26
3120	1.44
5160	1.61
9930	1.77
1.55e4	1.86
2.50e4	1.88
3.50e4	1.90

Note: Numeric values — like the minimum and maximum **B** and **H** values — may be entered and displayed in Ansys Electromagnetics Suite's shorthand for scientific notation. For instance, **35000** could also be entered as **3.5e4**. When entering numeric values, you can use either notation.

5. The graph automatically updates as each data point is entered. The software automatically fits a curve to the points you entered and displays a list of all B-H curve points, as shown below:

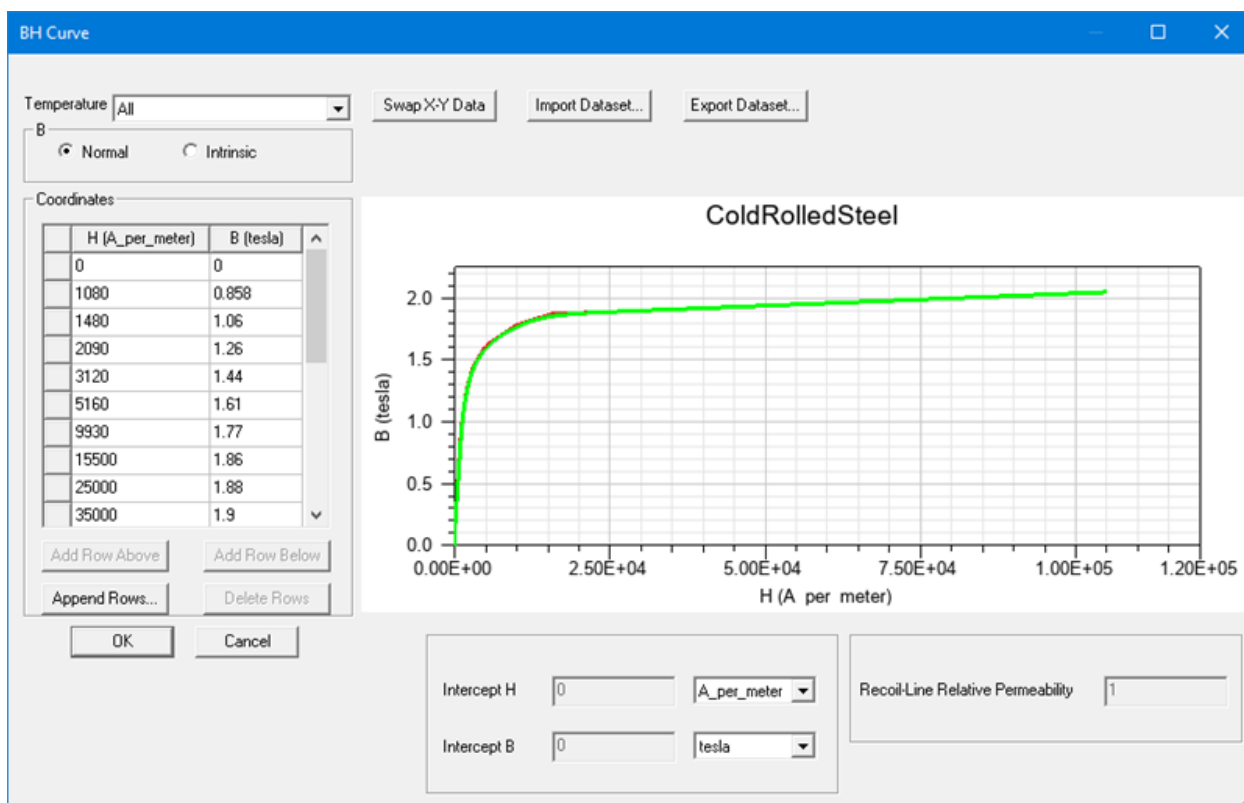

6. After you enter the last value, press **Enter** to exit data entry mode, and click **OK** to return to the **View/Edit Material** window.

Assign ColdRolledSteel to the Yoke and Bonnet

Now that you have completed the B-H curve entry, enter **ColdRolledSteel** into the database and assign it to the selected objects:

To save and assign the new material:

1. Click **OK** in the **View/Edit Material** window to save the material properties you have entered for **ColdRolledSteel** — including the B-H curve you have just defined — and add it to the material database.

ColdRolledSteel then appears highlighted in the database listing. The word **Project** appears next to it in the **Location** field, indicating that this material is specific to the **Solenoid** project.

2. Click **OK** to assign **ColdRolledSteel** to the Yoke and Bonnet.

Assign Neo35 to the Core

Next, create a new material **Neo35**, and assign it to the Core. **Neo35** is a permanently magnetic material.

Note: In the actual solenoid, the core was assigned the same material as the plugnut. However, for this problem, a permanent magnet is assigned to the core to demonstrate how to set up a permanent magnetic material.

Select the Object and Create the Material

To select the Core and create the material:

1. Select **Core** in the history tree.
2. Click the Material Value field in the **Properties** window and select **Edit**.
3. In the Select Definition dialog box, select **Add Material**. The **View /Edit Material** window is displayed.
4. Under **Material Name**, change the name of the new material to **Neo35**.

Select Independent Material Properties

In magnetostatic problems, only two of the four available material properties need to be specified. In Maxwell, you may enter only the permeability(μ) and the magnetic coercivity(H_c). The values of the other two properties are dependent upon these properties, according to the relationships shown below.

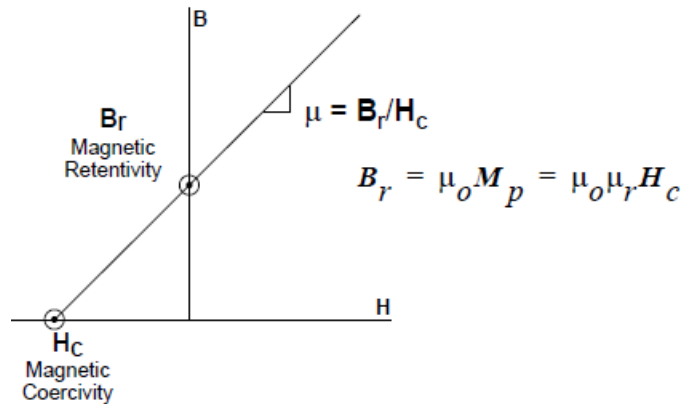

The values of the other two properties, magnetic retentivity, B_r , and magnetization, M_p , are computed using the relationships shown above. You may use the **Calculate Properties for** drop-down menu to calculate one set of properties from the other.

To calculate the properties to be entered:

1. From the **Calculate Properties for...** drop-down menu, select **Permanent Magnet**. The **Properties for Permanent Magnet** window appears.
2. Enter **1.05** in the **Mu** (relative permeability) field but do not press **Enter**.
3. Click on the check box next to **Hc** to deselect it.
4. Click on the check box next to **Br/Mp** to select it.
5. Enter **1.25** in the **Br** (magnetic retentivity) field and press the **Tab** key or use the mouse to change the field focus. Values automatically appear in the remaining fields.
6. Click **OK** to accept all the values and close the window. When using the Calculate Properties window, all data is automatically transferred when the window closes.

The View/Edit Material window should now have the values for **Relative Permeability** and **Magnetic Coercivity**.

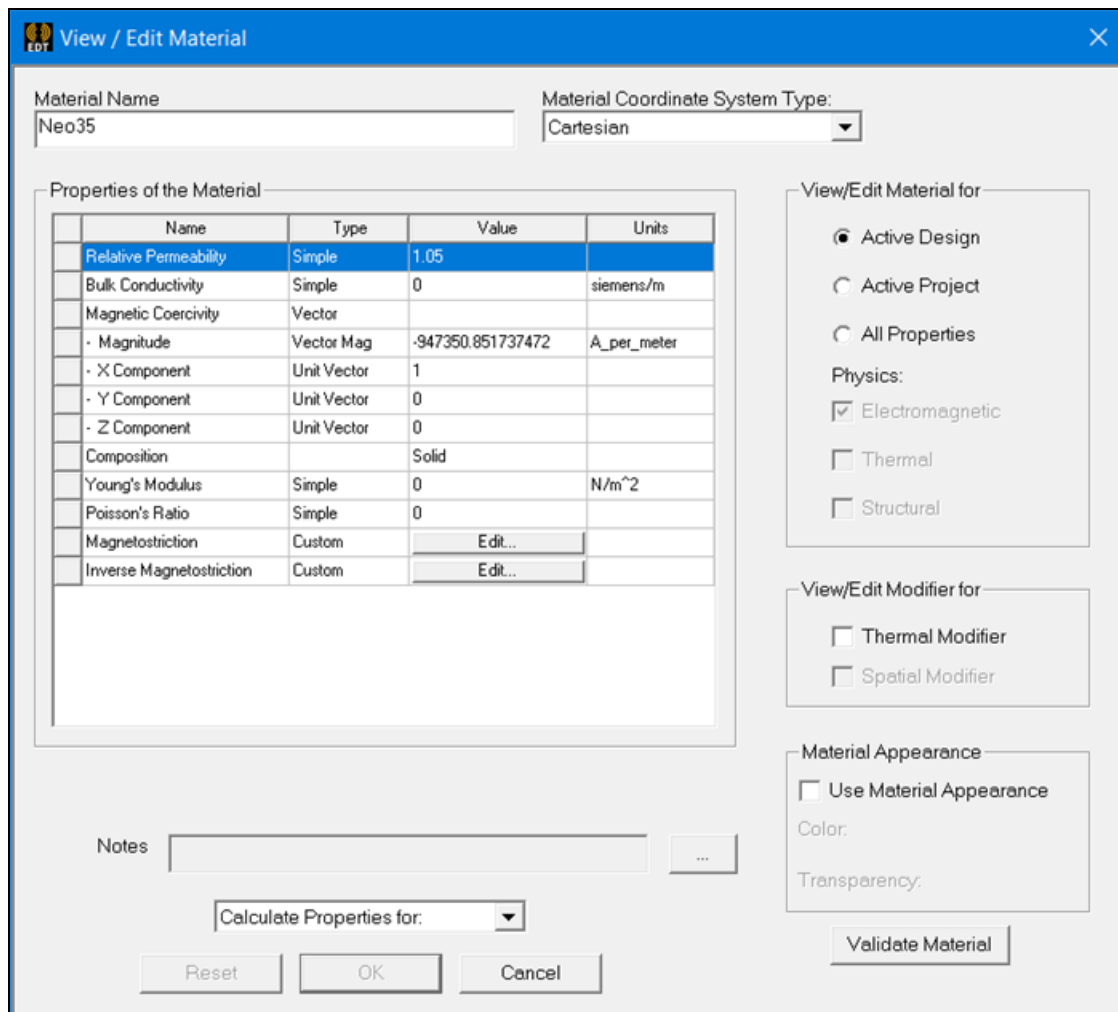

Manually Enter Material Properties

Optional - To enter the properties for Neo35 manually:

1. Enter **1.05** in the **Mu** field.
2. Enter **-947350.85** in the **Hc** field.

Because the **Hc** (magnetic coercivity) is a vector quantity, the window will update with entry fields for the **X**, **Y**, and **Z** vector components to specify the direction of the vector.

Note: By default, most material properties in the database shipped with Maxwell will be oriented along the x-axis (**1, 0, 0**) when a vector orientation is required. Other orientations require the user to create a coordinate system and align the material with it in order to change the orientation vector once it has been specified in the material database.

Also, verify that the **Material Coordinate System Type** drop-down menu at the top of the window is set to **Cartesian**.

3. Click **OK**. **Neo35** is now listed as a local material in the database.

Assign Neo35 to the Core

Now that you have created the material **Neo35**, all that remains is to assign it to the core and specify the direction of magnetization.

By default, the direction of magnetization in materials is along the R-axis (or the x-axis). However, in this problem, the direction of magnetization in the core points along the positive z-axis. To model this, you must change the direction of magnetization to act at a 90° angle from the default.

To assign **Neo35** to the core:

1. Make certain that **Neo35** is highlighted in the **Material** list.
2. Click **OK** in the **Select Definition** window to assign the material **Neo35** to the **Core** object. In the **Properties** window, the **Orientation** property is automatically set to **Global**.

Create a Relative Coordinate System for the Magnet Orientation

The material properties must be aligned with a coordinate system, so you will now create one that is rotated 90°.

1. Click **Modeler > Coordinate System > Create > RelativeCS > Rotated**.
2. Using the mouse, align the **X-axis** of the new coordinate system with the **Z-axis** of the global coordinate system and click the mouse.

A new coordinate system **RelativeCS1** is created and automatically set to be the current working coordinate system.

Note: You may also use keyboard entry mode to specify the new coordinate system by pressing **Tab** on your keyboard. This will shift the focus to the data entry area at the bottom of the screen where you can enter exact values for the coordinate point, in this case (0, 0, 1). Pressing the **Tab** key also allows you to navigate between the **X**, **Y** and **Z** entry boxes quickly.

Complete the Alignment of the Magnet

1. Make sure the **Core** object is selected.
2. In the **Properties** window select the Value cell next to **Orientation**. A drop-down menu is displayed listing the coordinate systems available in the project.

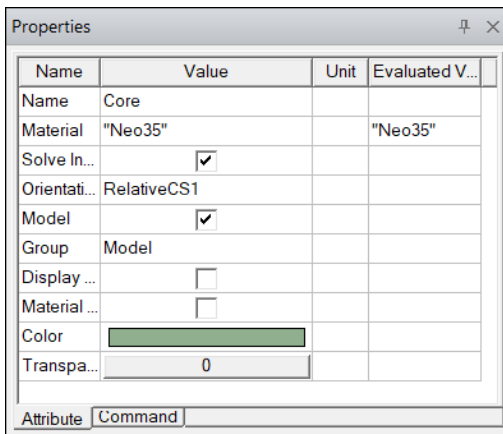

3. Select **RelativeCS1**. This completes the alignment of the magnetic coercivity for the **Core** object.
4. You may wish to return to the Global Coordinate system. To do so, in the history tree, expand the **Coordinate Systems** entry, and select **Global**, as shown in the following figure.

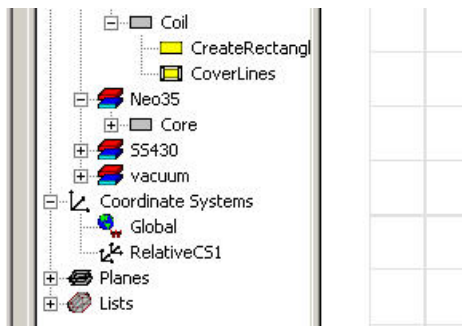

Create SS430 Material and Assign to Plugnut

Next, create a new material — SS430 — for the plugnut. Like the material **ColdRolledSteel**, it is a nonlinear material whose relative permeability must be defined using a B-H curve. The first step includes selecting the plugnut and creating the material.

Select Objects and Create Material

To select the plugnut, and create the material:

1. Expand the **Model\Solids** entry in the history tree, and select **Plugnut**.
2. Click the Material Value field in the **Properties** window and select **Edit**.
3. In the **Select Definition** window, click **Add Material**.
4. Under **Material Name**, change the name of the new material to **SS430**.
5. Select the **Relative Permeability** type field and change it from Simple to **Nonlinear**.

The value field changes to a button labeled **BH Curve**.

Define the B-H Curve for SS430

1. To define the B-H curve for SS430, click the **B-H curve** button. The **B-H Curve Entry** window appears.
2. Enter the points in the B-H curve according to the table below:
 - a. Select the **H** column, row 1 and enter **0.0**. Press the **Tab** key to accept the entry and move to the next cell.
 - b. Use the **Append Rows** button to add **9** additional rows to the table to accommodate the data below.
 - c. Enter the following points using keyboard entry.

Table 5:

H	B
0.0	0.0
143	0.125
180	0.206
219	0.394
259	0.589
298	0.743
338	0.853
378	0.932
438	1.01
517	1.08

H	B
597	1.11
716	1.16
955	1.20
1590	1.27
3980	1.37
6370	1.43
1.19e4	1.49
2.39e4	1.55
3.98e4	1.59
7.69e4	1.645

- After you enter the last value press **Enter** to accept the last data point and click **OK** to return to the **View/Edit Material** window.

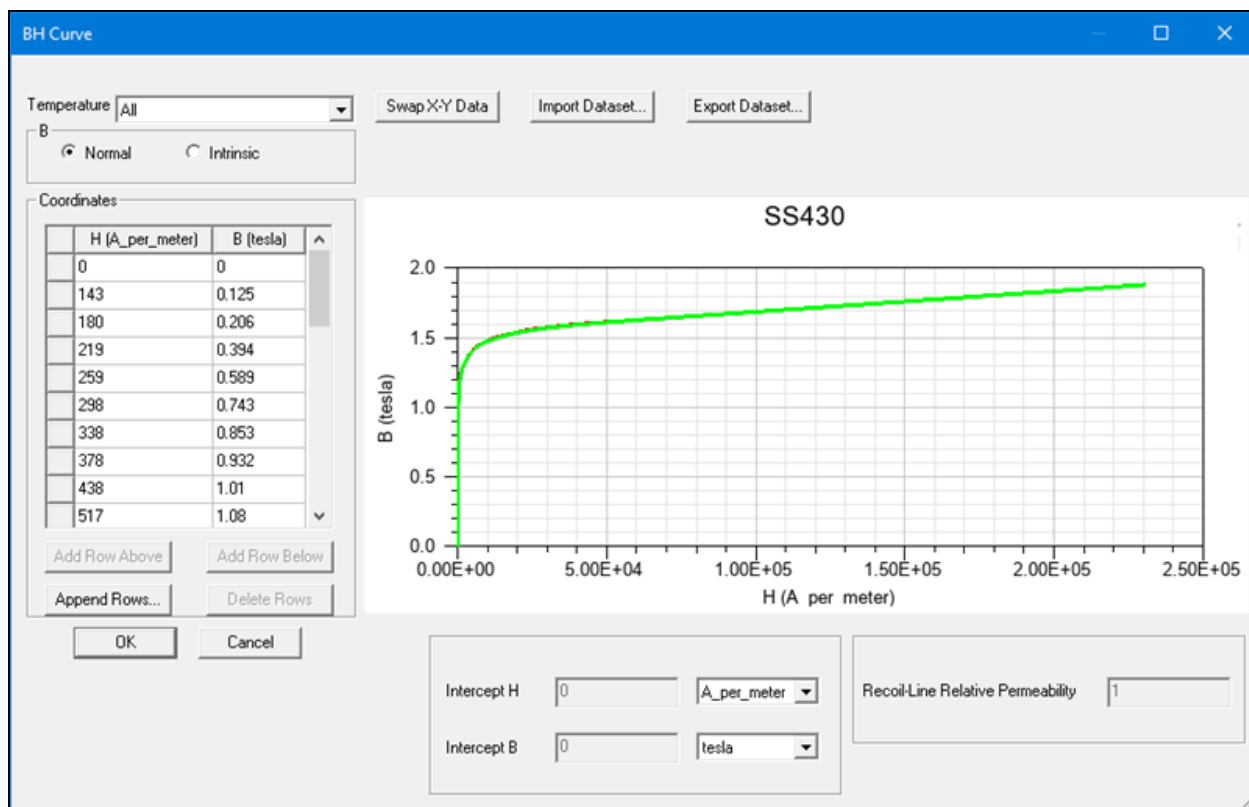

Assign SS430 to the Plugnut

Finally, add **SS430** to the material database, and assign it to the selected object:

To save and assign **SS430**:

1. Click **OK** in the **View/Edit Material** window to save the material properties you have entered for **SS430** — including the B-H curve you have just defined — and add it to the material database.
2. Make certain **SS430** is highlighted. Click **OK** in the **Select Definition** window to save the material attributes you entered for **SS430** and assign it to the **Plugnut** object.

Accept Default Material for Background

Accept the following default parameters for the background object **Bgnd**:

- The object **Bgnd** is the only object that will use the material assigned by default. At the time an object is created, a default material is assigned and is visible in the **Properties** window.
- The default material, vacuum, is acceptable to use for the **Bgnd** in this model.

Note: During the model creation process, the material may be assigned immediately to the object before continuing to create the next object. This may have some advantages because copying an object with a material assigned will preserve the material assignment for the copy objects and may reduce the need for material assignments.

Set Up Boundaries and Current Sources

After you set material properties, you must define boundary conditions and sources of current for the solenoid model. Boundary conditions and sources are defined through the Boundaries and Excitations entries in the Project Manager tree or through the **Maxwell 2D > Boundaries** and **Maxwell 2D > Excitations** menus, respectively.

By default, the surfaces of all objects are Neumann or natural boundaries. That is, the magnetic field is defined to be perpendicular to the edges of the problem space and continuous across all object interfaces. To finish setting up the solenoid problem, you must explicitly define the following boundaries and sources:

- The boundary condition at all surfaces exposed to the area outside of the problem region. Because you included the background as part of the problem region, this exposed surface is that of the object **Bgnd**. The solenoid is assumed to be very far away from other magnetic fields or sources of current, so those boundaries will be defined as “balloon boundaries.”
- The source current on the coil. The coil has 10,000 turns of wire, and one ampere flows through each turn, so the net source current is 10,000 amperes.

Note: Maxwell 2D will not solve the problem unless you specify some type of source or magnetic field — either a current source, an external field source using boundary conditions, or a permanent magnet. In this problem, both the permanent magnet assigned to the core and the current flowing in the coil act as magnetic field sources.

Types of Boundary Conditions and Sources

There are two types of boundary conditions and sources that you will use in this problem:

- | | |
|-------------------------|--|
| Balloon boundary | Can only be applied to the outer boundary. Models the case in which the structure is infinitely far away from all other electromagnetic sources. |
| Current source | Specifies the DC source current flowing through an object in the model. |

You will assign boundary conditions and sources to the following objects in the solenoid geometry:

- | | |
|-------------|---|
| Bgnd | At the outer boundary of the problem region, the outside edges of this surface are to be ballooned to simulate an insulated system. The edge along the Z axis will not be assigned because it is the axis of rotation for this Cylindrical about Z problem. |
| Coil | This object is to be defined as a 10,000-amp DC current source. The current flows in the positive perpendicular direction to the cross-section. |

Set Source Current on the Coil

Before you identify a boundary condition or source, you must first identify the object or surface to which the condition is to be applied. In this section, you will pick the coil as a source and then assign a current to it.

To specify the current flowing through the coil:

1. Select the **Coil** object by clicking on the object in the Modeler window or selecting the object from the **Model\Solids** entry in the history tree.
2. Select **Maxwell 2D > Excitations > Assign > Current**. The Current Excitation window appears.
3. Enter **10000** in the Value field, and ensure the units are set to Amps.
4. Ensure the **Ref. Direction** is set to **Positive** to indicate current flowing in the positive PHI direction, in this case, into the screen.

Note: Positive is in the positive Z direction for XY problems, and positive PHI for RZ problems.

5. Click **OK** to complete the assignment of the source named **Current1** to the **Coil** object.

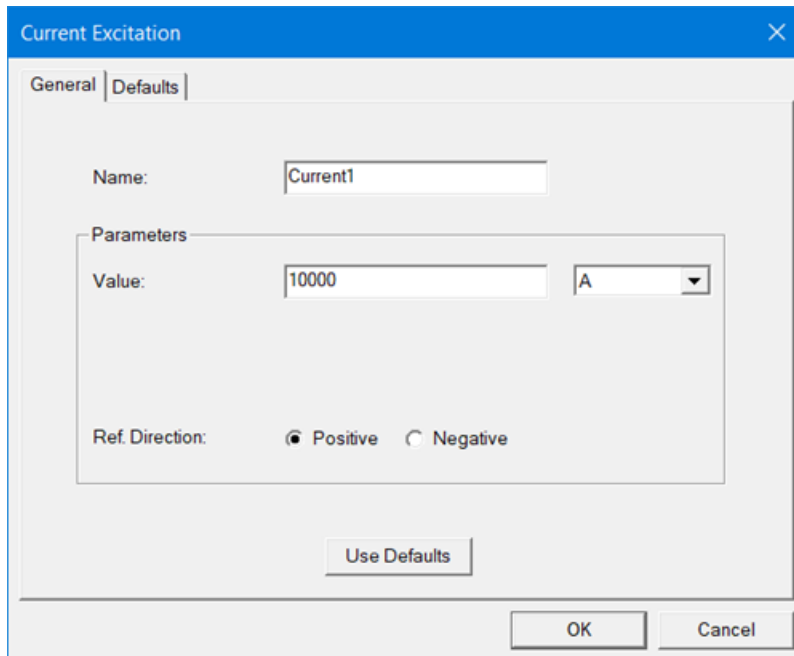

6. **Current1** is now listed under the **Excitations** section of the Project Manager tree.

Assign Balloon Boundary to the Background

The structure is a magnetically isolated system. Therefore, you must create a balloon boundary by assigning balloon boundaries to the outside edges of the background object.

To select the edges of the background to use as a boundary:

1. Click **Edit > Selection Mode > Edges**, select the three edges of the Bgnd object that correspond to the open region as shown. Click the first edge and then click the remaining edges while holding down the **Ctrl** key.

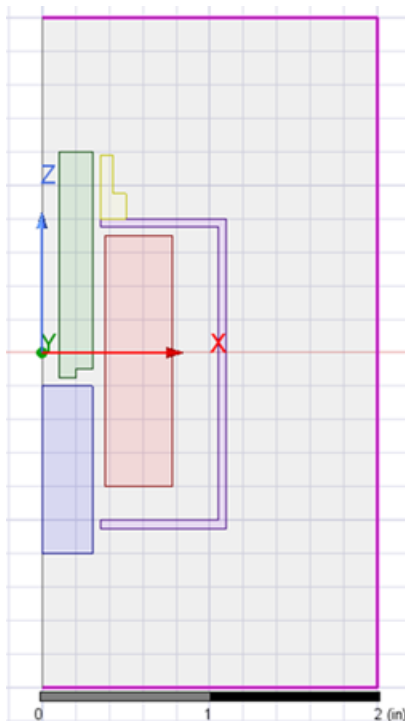

2. Click **Maxwell 2D > Boundaries > Assign > Balloon**.
3. The Balloon Boundary dialog box appears with **Balloon1** in the **Name** field. Click **OK** to accept the default name.

Note: In Cartesian (XY) models, all outer edges may be defined as boundaries. However, in axisymmetric (RZ) models, the left edge of the problem region cannot be assigned a balloon boundary condition because the solenoid model is axisymmetric (representing the cross-section of a device that's revolved 360 degrees around its central axis). Instead, it automatically imposes a different boundary condition to model that edge as an axis of rotational symmetry.

4. **Balloon1** now shows up in the Project Manager tree under the Boundaries section.

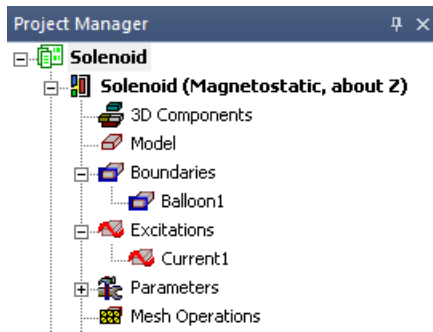

You are now ready to set up the force computation for the model.

Set Up Force Computation

One of your goals for this problem is to determine the force acting on the core of the solenoid. To find the force on this object, you must select it and assign the force parameter. The force (in newtons) acting on the core will then be computed during the solution process.

To select the core object for the force computation:

1. Click **Edit > Selection Mode > Objects**. Click on the **Core** object in the modeler window.
2. Click **Maxwell 2D > Parameters > Assign > Force** in the menu. The **Force Setup** window appears.
3. Click **OK** to select the default name and assign the force computation to the **Core** object.
4. The force computation now appears in the Project Manager tree under **Parameters**.

You are now ready to set up the inductance computation.

Set Up Inductance Computation

In addition to the force on the core, the coil inductance is of interest.

To set up the inductance computation:

1. Click **Maxwell 2D > Parameters > Assign > Matrix** in the menu. The **Matrix** setup window appears.
2. Click the **Include** check box next to **Current1** to select the current excitation for use in a matrix calculation.

Because there is only one excitation defined in this problem, the return current must be set to the default (infinite); however, in an axisymmetric model the current returns in the coil itself because it is rotated 360 degrees about the Z-axis.

3. Click **OK**.
4. Click **File > Save** to save all the changes for boundary, excitation, and parameter setup.

You are now ready to configure the solution criteria.

5 - Generating a Solution

Now you are ready to specify solution parameters and generate a solution for the solenoid model. You will do the following:

- View the criteria that affect how Maxwell 2D computes the solution.
- Generate the magnetostatic solution: The axisymmetric magnetostatic solver calculates the magnetic vector potential, \mathbf{A}_ϕ , at all points in the problem region. From this, the magnetic field, \mathbf{H} , and magnetic flux density, \mathbf{B} , can be determined.
- Compute the force on the core. Because you requested force using the **Parameters** option, the force computation automatically occurs during the general solution process.
- View information about how the solution converged and what computing resources were used.

Add Solution Setup

Use the default criteria to generate the solution for the solenoid problem.

1. In the Project Manager tree, right-click **Analysis** and select **Add Solution Setup**.

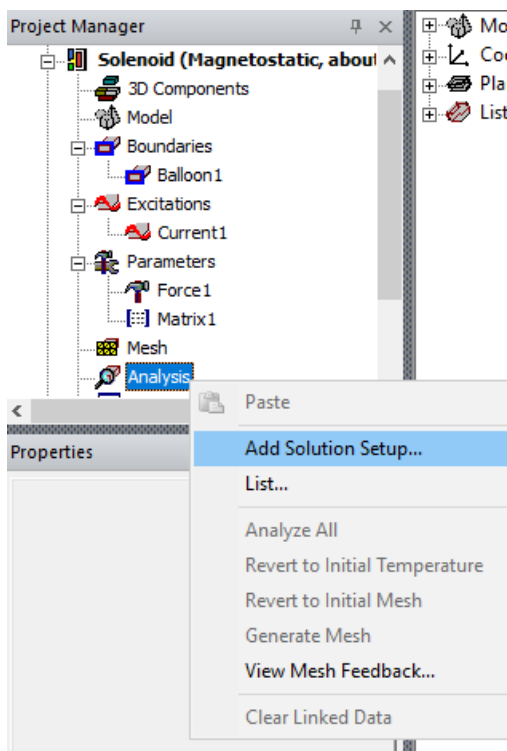

The **Solve Setup** window appears:

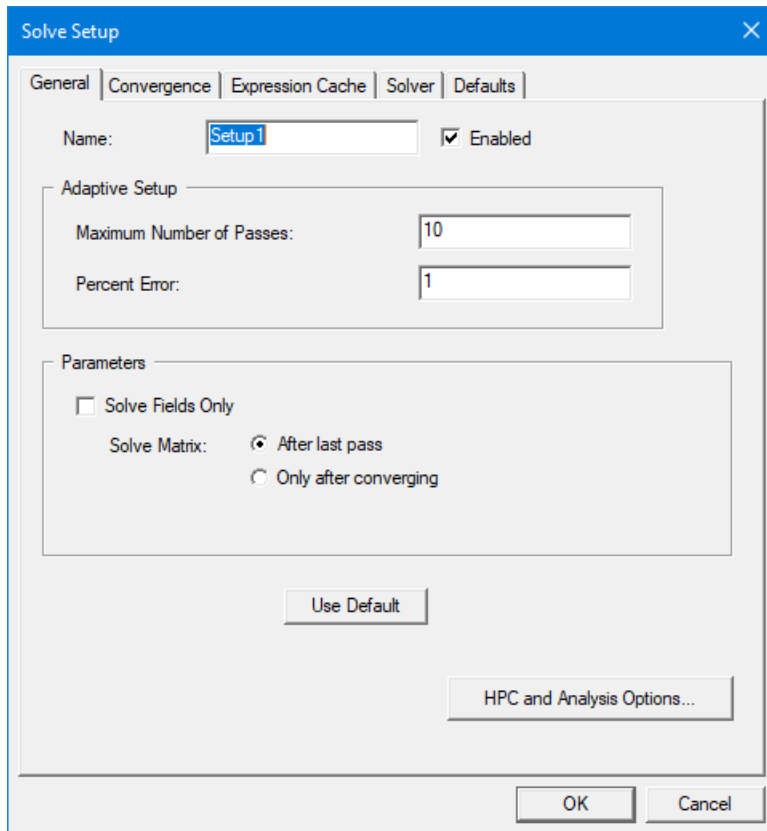

When the system generates a solution, it explicitly calculates the field values at each node in the finite element mesh and interpolates the values at all other points in the problem region.

Adaptive Analysis

In the **Adaptive Setup** section of the **General** tab, configure the following to have the system adaptively refine the mesh and solution:

1. Enter **10** in the **Maximum Number of Passes** field for the maximum number of adaptively refined solution passes to complete.

This setting instructs the system to solve the problem iteratively, refining the regions of the mesh in which the largest error exists. Refining the mesh makes it more dense in the areas of highest error, resulting in a more accurate field solution.

Note: After each iteration, the system calculates the total energy of the system and the percentage of this energy that is caused by solution error. It then checks to see if the number of requested passes has been completed, or if the percent error *and* the change in percent error between the last two passes match the requested values.

2. Leave **Percent Error** set to its default value of **1%**.

The **Percent Error** field tells the software what target error to achieve within the number of passes allowed. If this percent error is reached, the solution process will terminate even though additional adaptive passes may be available. In most cases, the default refinement value is acceptable to provide an accurate solution in reasonable time.

If any of these criteria has been met, the solution process is complete, and no more iterations are done.

Parameters

The **Parameters** section of the **General** tab allows the user to specify when requested parameters should be solved. For this solution, make sure that the **Solve Fields Only** box is not checked, which will allow the force solution to be calculated after each adaptive solution.

Mesh Refinement Criteria

On the **Convergence** tab, the **Standard** section refers to the mesh refinement to be used during adaptive analysis.

1. Set the **Refinement Per Pass** to **30%**, which tells the software to increase the number of mesh triangles by up to 30 percent after each adaptive solution.
2. Set **Minimum Number of Passes** to **2** to force the system to solve at least two passes, regardless of the solution accuracy calculated after the initial solution.
3. Set the **Minimum Converged Passes** to **1**. Setting a higher number will force multiple successive solutions to be below the Percent Error criteria before stopping the solution process.

Solver Residual

On the **Solver** tab, leave the **Nonlinear Residual** field set to **0.0001**.

This value specifies how close each solution must come to satisfying the equations that are used to compute the magnetic field. All other fields should remain at their default values.

Click **OK** at the bottom of the window to complete the **Solve Setup** process.

Validate Design

Before running a simulation, it is best to validate its setup.

1. From the **Maxwell 2D** menu, select **Validate Check**. Alternatively, from the **Simulation**

tab, you can click the **Validate** icon.



The **Validate Check** tool runs, and after it is complete, the Validate Check window appears:

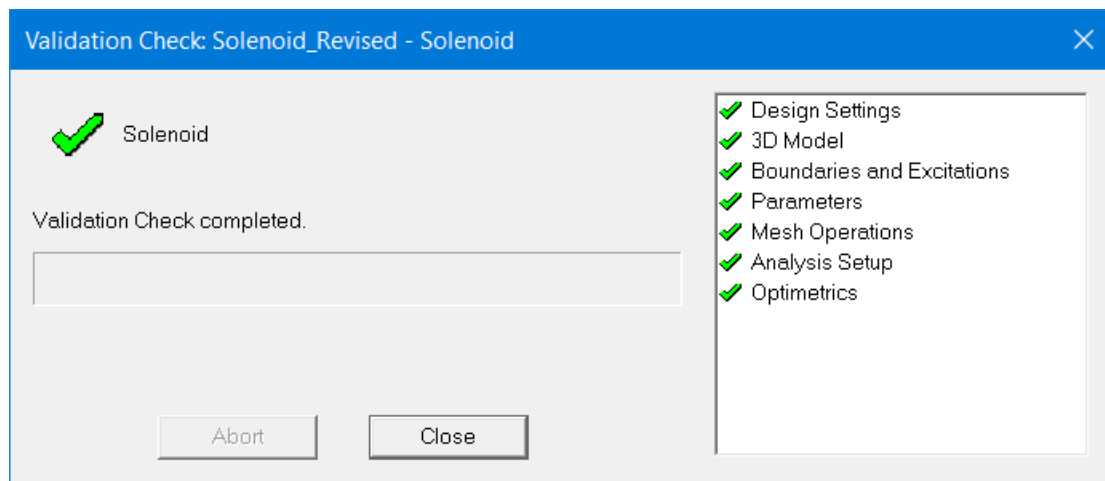

For this model, we see that the model, the design settings, and the simulation parameters were checked and validated. If the tool finds any problem with your design, it will be reported in this window. Make sure to address any of these issues before you run your simulation.

Start the Solution

Now that you have set up the solution parameters, the problem is ready to be solved.

To start the solution, underneath the **Analysis** entry in the Project Manager tree, right-click **Setup1 > Analyze**.

The system creates the initial finite element mesh for the solenoid structure. A progress bar appears in the **Progress** box at the bottom of the screen. It shows the system's progress as it generates the mesh and computes the adaptive solutions.

The solution may be stopped by right-clicking on the progress window as shown.

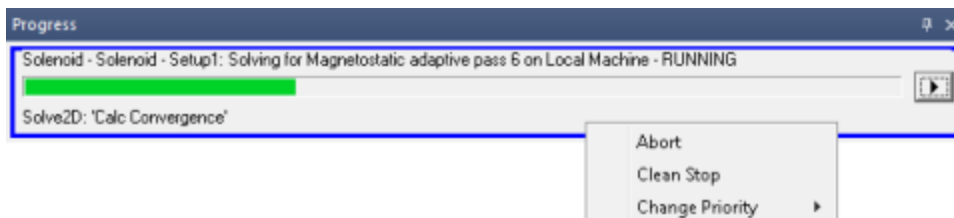

Values you obtain for percent energy error, total energy, or force may differ slightly from the ones given in this guide. Depending upon how closely you followed the directions for setting up the solenoid model, the results that you obtain should be approximately the same as the ones given here.

Once the solution process has completed, or in the case of an error, the Message Manager window will display information regarding the reason for the solution process termination. In this case you should see the following message:

```
Normal completion of simulation on server: Local Machine
```

Note: After a solution is generated, the system will invalidate your solution if you change the geometry, material properties, or boundary conditions of the model. Therefore, you must generate a new solution if you change the model.

Monitoring the Solution

You may monitor the solution progress while the simulation is running by right-clicking on the solution setup entry in the Project Manager. The following information is available while the simulation is running.

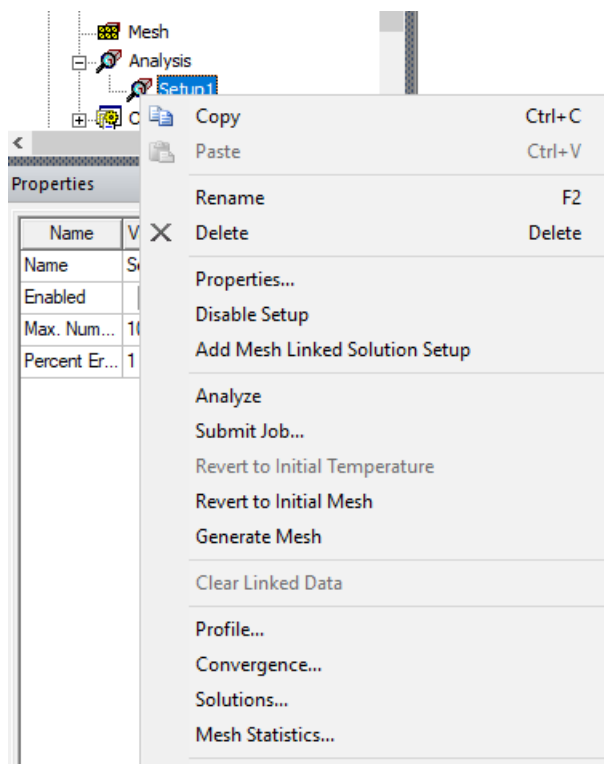

- **Profile** displays the **Profile** tab of the Solution window, which lists the computer resource (memory and computation time) usage for each process in the simulation and the running total.
- **Convergence** shows the mesh size, error calculation, and delta energy for each adaptive pass in the solution.

Note: If a problem does not begin to converge after several adaptive passes, the problem is probably ill-defined — for instance, boundary conditions may not have been specified correctly. If this ever happens, do the following to interrupt the solution process:

1. Right-click the **Progress Bar**, and select **Abort**.
2. Check the problem definition, and then solve the problem again.

- **Solutions** displays the results of the parameter calculations; in this case, the force calculated on the **Core**.
- The **Mesh Statistics** option displays the **Mesh Statistics** tab of the Solution window. It displays the number of triangles and various triangle properties for each object in the solution.

Viewing Convergence Data

Now that the solution has completed, you can review the solution information to judge the accuracy and suitability of the solution. Right-click on **Setup1** in the Project Manager and select **Convergence** to monitor how the solution is progressing. Convergence information appears as shown below. In this example, the system has completed five adaptive passes.

Simulation: Setup1

Design Variation: curr='10000A' deltagap='0in'

Profile | **Convergence** | Winding | Loss | Force | Matrix | Mesh Statistics

Pass	Triangles	Total Energy (J)	Energy Error (%)	Delta Energy (%)
1	346	2.0203	9.2478	N/A
2	474	2.0113	4.4597	0.44462
3	617	2.0121	2.2175	0.037135
4	806	2.0119	1.2904	0.007565
5	1048	2.0118	0.73137	0.0047518

Number of Passes
Completed 5
Maximum 10
Minimum 2

Energy Error/Delta Energy (%)
Target (1, 1)
Current (0.73137, 0.0047518)

View: Table Plot

Export...

Default Settings
Save Defaults Clear Defaults

Close

Note: Do not be alarmed if the values you obtain for number of triangles, percent energy error, total energy, delta energy differ slightly from the ones given in this guide. The results that you obtain should be approximately the same as the ones given here.

Solution Criteria

Information about the solution criteria is displayed on the left side of the convergence display.

- Number of passes** Displays how many adaptive passes have been completed and still remain.
- Target Error** Displays the percent error value — **1%** — that was entered during Add Solution Setup.
- Energy** Displays the percent error from the last completed

Error	solution — in this case, 0.73137% . Allows you to see at a glance whether the solution is close to the desired error energy. Because this value is less than the Target Error , the solution was considered to be converged.
Delta Energy	Displays the change in the percent error between the last two solutions — in this case, 0.0047518% .

Completed Solutions

Information about each completed solution is displayed on the right side of the screen.

Note: Your individual solution may differ slightly due to machine differences and meshing differences with each release of the software.

Pass	Displays the number of the completed solutions. In the previous figure, 5 adaptive passes were completed.
Triangles	Displays the number of tetrahedrons in the mesh for a solution. In the previous figure, the mesh used for the fifth solution had 1048 triangles.
Total Energy (J)	Displays the total energy of a solution in Joules. In the previous figure, the total energy for the fifth solution was 2.0118 Joules.
Energy Error (%)	Displays the percent energy error of the completed solutions. In the previous figure, the energy error for the fifth solution was 0.73137% .
Delta Energy (%)	Displays the change in Total Energy between the current and previous expressed as a percentage of the previous pass energy. In the previous figure, the Delta Energy for the fifth pass was 0.0047518% .

Plotting Convergence Data

By default, convergence data is displayed in table format as shown in the previous figure. This data can also be displayed graphically.

To plot the Energy Error computed during each adaptive pass:

1. On the **Convergence** tab, click the **Plot** radio button.
2. Use the drop-down menu to select **Energy Error** for the Y-axis.

The following plot appears:

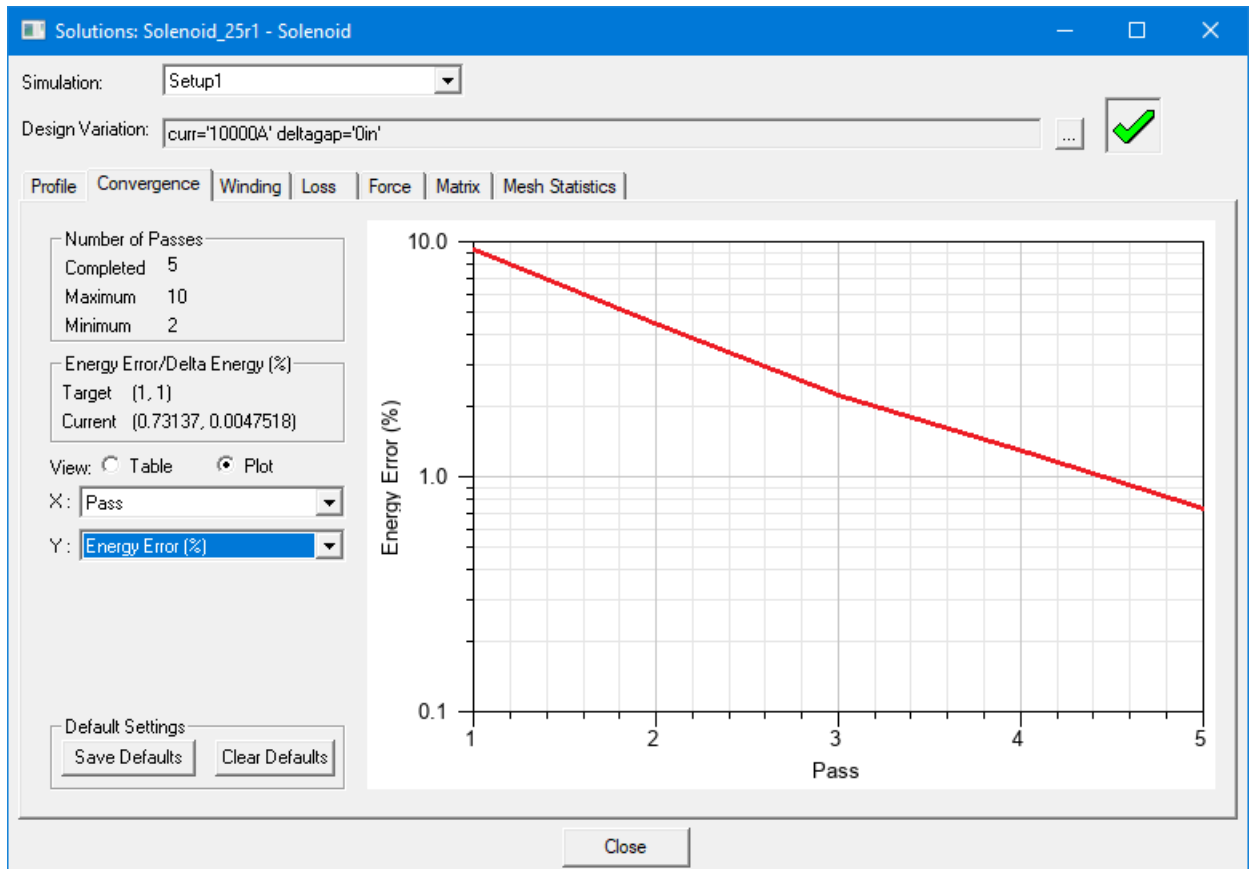

Displaying this data graphically often makes it easier to see how the solution is converging.

- Optionally, use the other commands under **Convergence Display** to plot the number of triangles, total energy, or delta energy for all adaptive passes.

Viewing Statistics

Click the **Profile** tab to see what computing resources were used during the solution process. The following screen appears:

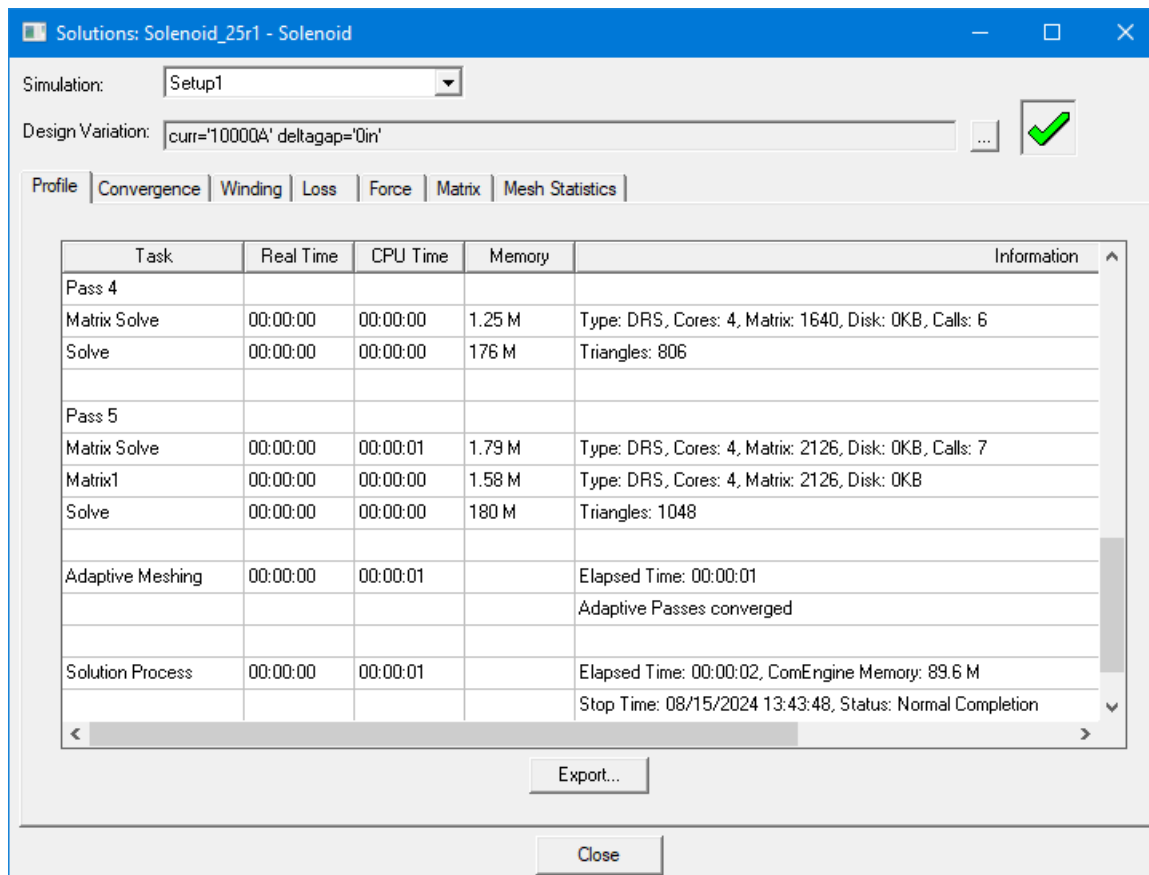

The time that the solution process began is displayed at the top of the box. Beneath it, the following information is displayed for each adaptive field solution and mesh refinement step that was completed:

- Task** Displays the name of the system command that was used
- Real time** Displays the time taken to complete the step
- Cpu time** Displays the amount of time taken by the CPU (central processing unit) to complete the step
- Memory** Displays the amount of memory used
- Information** Displays the of number of triangles, number of CPUs, and various other information for the process

If more data is available than can fit on a single screen, scroll bars appear.

Click the **Close** button at the bottom of the Solutions window. You are now ready to move on to post processing the solution and evaluating the fields and parameters calculated for this model.

6 - Analyzing the Solution

Now that you have generated a magnetostatic solution for the solenoid problem, you can analyze it using Maxwell 2D's post-processing features. In this section, you will

- examine the computed force values
- plot the magnetic flux and magnetic fields in and around the solenoid

View Force Solution

Now that the solution is complete, examine the results of the force computation.

To view the force results, right-click the **Force1** entry under the **Parameters** section of the Project Manager tree, and select **View Solution**.

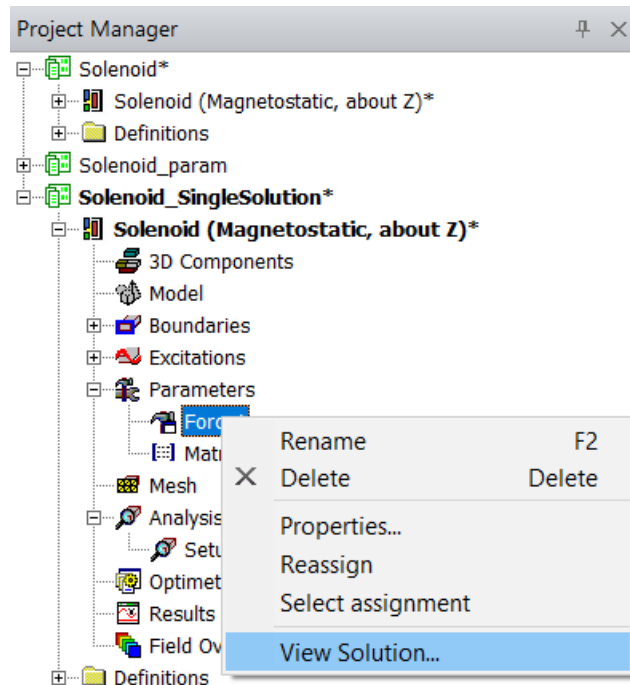

The final force value computed during the adaptive solution appears as shown below. Note that your values may differ slightly from those shown:

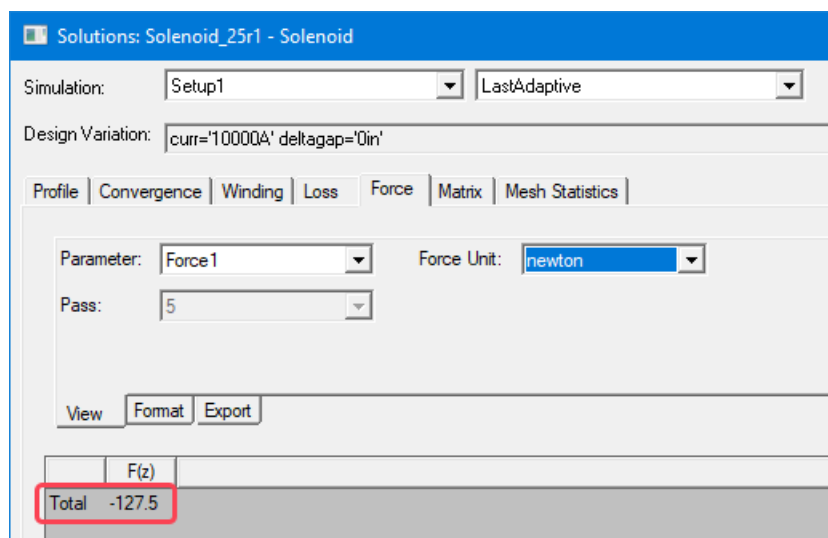

The net force on the core is approximately 128 newtons, acting in the negative Z direction (pulling the core down into the solenoid). There is no component of force in the R direction because of the axial symmetry. Click **Close** to dismiss the window.

Plot the Magnetic Field

You will now create a field plot of the Magnetic Field in the entire problem region.

1. You must first select one or several objects in the problem region on which to create a field plot. Click the mouse anywhere in the Modeler window and press **Ctrl + A**. This will select all objects in the model.
2. From the Field Overlays section of the Project Manager tree (or the **Maxwell 2D > Fields** menu), select **Fields > H > Mag_H** to plot the magnetic field magnitude throughout the selected problem region.

The **Create Field Plot** window appears. By default, **Mag_H** and all the **In Volume** objects are selected. Also note that the Solution field defaults to the **LastAdaptive** pass data to plot.

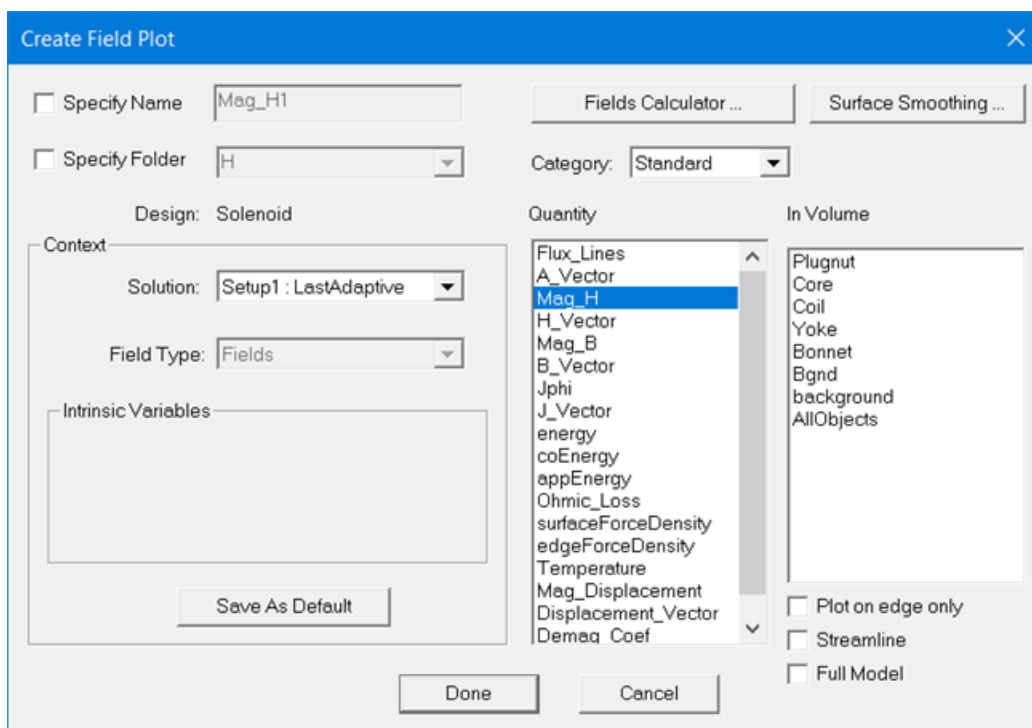

3. Uncheck the **Full Model** option; you only want to plot the symmetry model. If this option is checked, the software will plot the full model (with both sides of the symmetry).
4. *Optionally*, a plot on only the edge of the selected Volume may be obtained by checking **Plot on edge only**.
5. Click **Done**. The **Mag H** plot shown below appears.

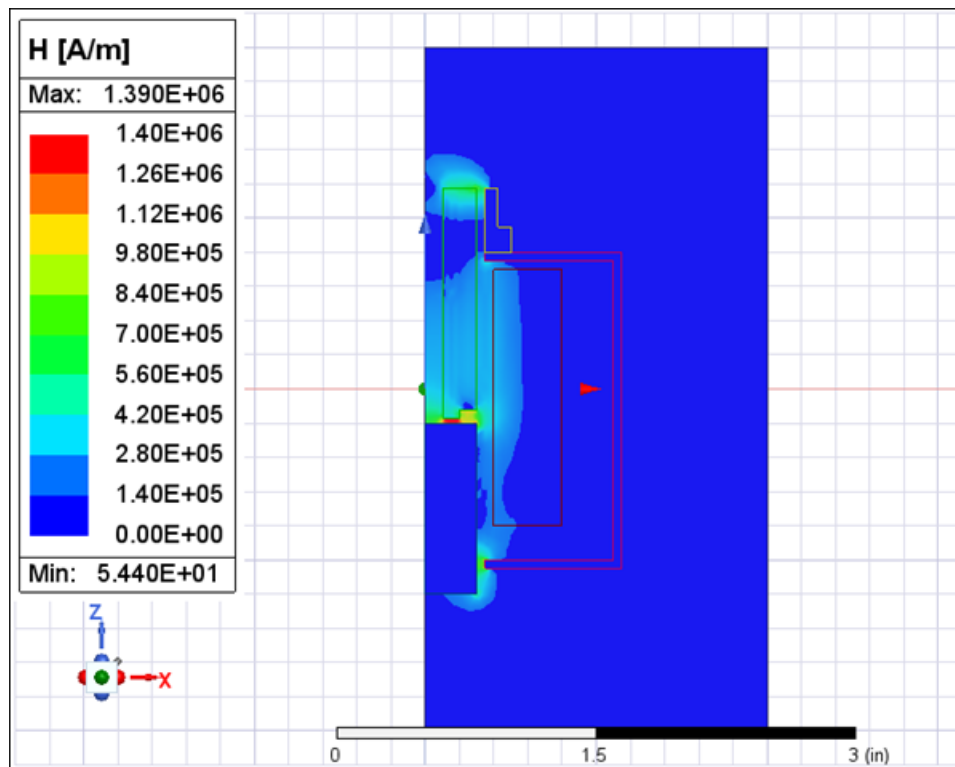

6. Double-click on the **color key** to display a window for modifying plot properties. Click the **Scale** tab.
7. Set the **Num Division** to **15**.
8. Click the **Use Limits** radio button and enter **1000** in the **Min** field as shown in the figure below.

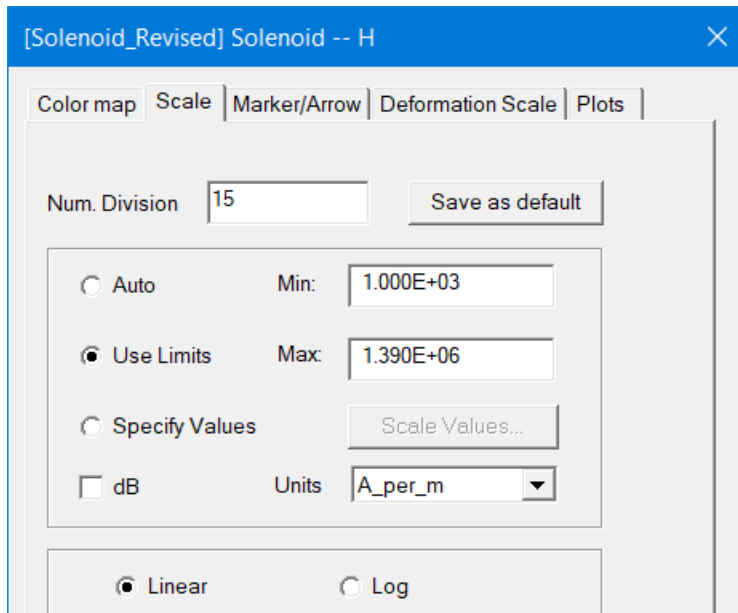

9. Click **Apply** and the plot will update with a new minimum field display.
10. Click **Close**. The plot should resemble the following one:

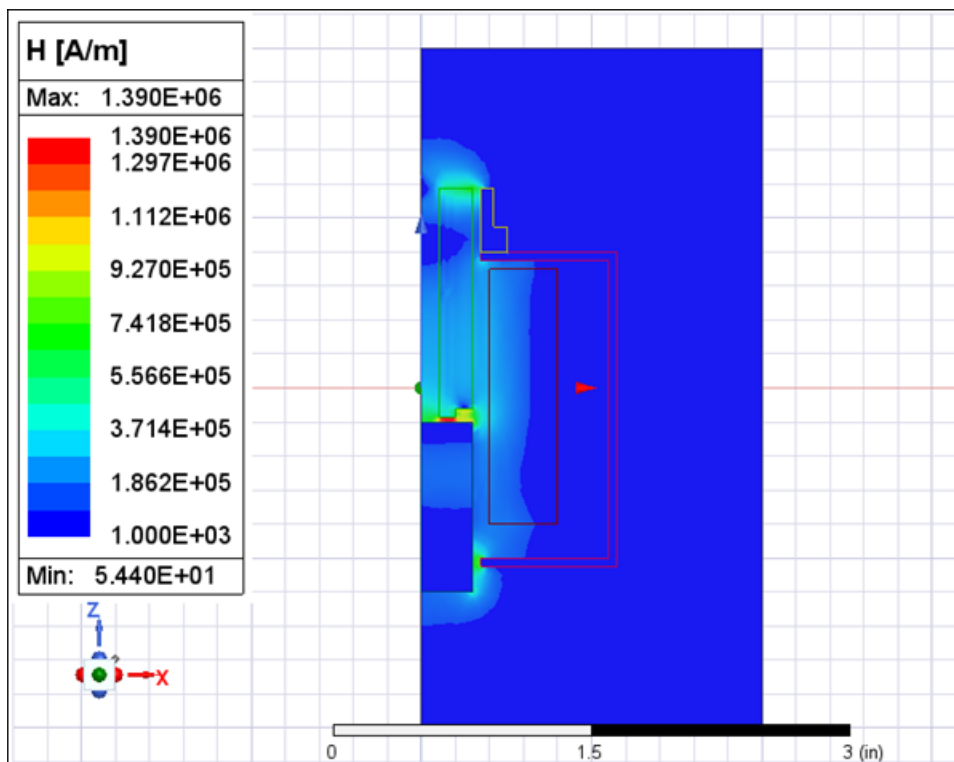

11. Click **File > Save** to save all of the operations up to this point.

7 - Adding Variables to the Solenoid Model

Now you are ready to use Maxwell to solve the solenoid problem parametrically. This chapter shows you how to do the following:

- Add a geometric variation to the solenoid model. This will define the distance between the core and the plugging as a variable that can be swept during the solution.
- Define a source current function and assign it to the coil
- Calculate the force acting on the core and the coil inductance as a function of core position and coil current during the solution.

The Solenoid Model

The geometric design variable that you are going to define in this chapter represents the gap increase from the nominal design between the solenoid's core and plugging. By varying the distance between these objects, you can model the solenoid's behavior over a range of core positions. During the solution, **deltagap** parameter will vary from 0.0 to 0.5 inches, representing a spacing between the core and plugging of 0.075 to 0.575 inches as shown. The core never actually touches the plugging — there is a minimum air space of 0.025 inches.

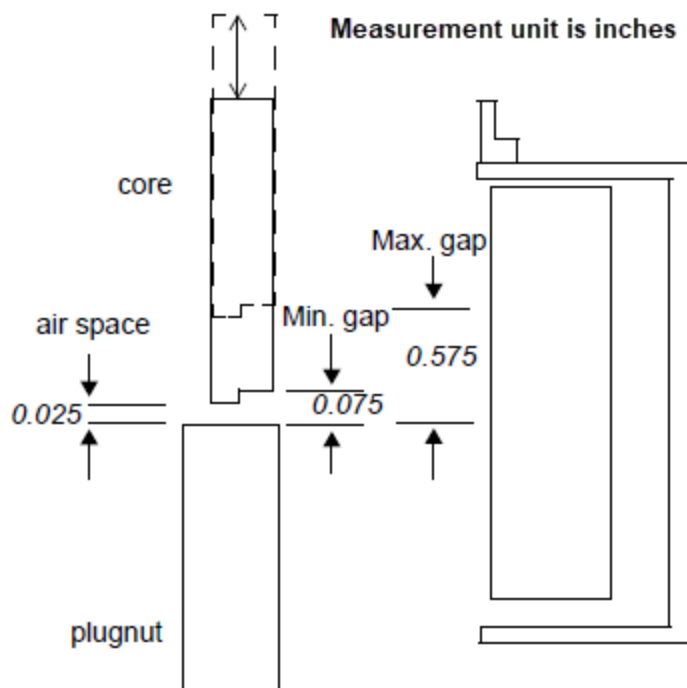

1. Choose **File > Save As** from the menu and save a copy of the project to **Solenoid_param**. This will become our parameterized project.

Adding Geometric Variables

There are many ways to parameterize a geometric model in Maxwell's modeler. For this example, you will use the **Edit > Arrange > Move** command and assign a variable to the move distance. The variable can then be modified by a parametric analysis to move the core location for the sweep analysis.

Other options for varying an object would be to use variables in place of exact coordinates in the rectangle command used to create the core as an example. Then the corners of the rectangle can be varied allowing the core to move and change shape as well. However, all variations of geometric parameterization use the basic procedure you will follow here:

- Assign a variable to one or several points in the creation of a geometric object.
- Provide a default value for the variable.
- Specify the variable is to be used for optimization, sensitivity, or tuning analysis. Local design variables are automatically available for parametric analysis.
- Indicate the range of values the variable may take during the parametric analysis.

Add a Variable to the Core Object

You will now add a simple linear movement to the **Core** object using the move command.

1. Select the **Core** object by clicking on it in the Modeler Window or by selecting it in the history tree.
2. Choose **Edit > Arrange > Move** from the menu. The modeler switches to move mode and prompts you for a reference point in the status bar.
3. Enter a reference point by clicking at the origin. Optionally, you may enter **(0, 0, 0)** in the keyboard entry area of the status bar and press the **Enter** key.
4. Enter a target point along the Z-axis by clicking the mouse along the axis. Optionally enter **(0, 0, 0.2)** in the keyboard entry area and press the **Enter** key.

Note: It is not important what points are selected for the move command. You are just creating the move command in the model history. The exact movement will be controlled by the variable you set up next.

5. After entering the target point, the properties window will update with the **Command** tab as shown.

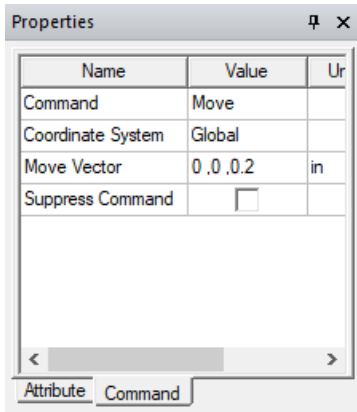

Alternatively, you may have the Properties dialog appear if you have the option **Edit Properties of New Primitives** set under the **Modeler Options** command

Select the Value field of the Move Vector row and enter **deltagap** in the **Z**-axis direction. In addition, make sure that the **X**-axis and **y**-axis movement is zero. Press **Enter**.

- The Add Variable dialog will be displayed indicating that you have entered a variable in a numeric data field.

Enter **0.0 in** into the value field of the dialog as shown.

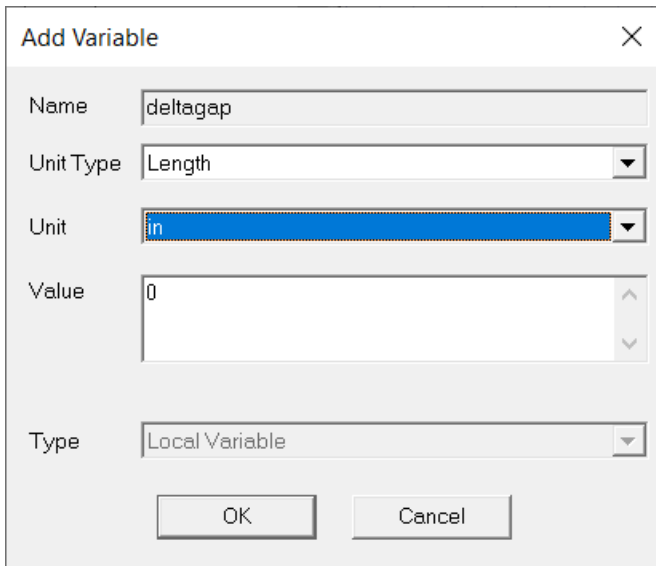

- Click **OK** to complete the geometric variable assignment.

Set the Coil Current to a Variable

Variables may be used in material, boundary and source excitations as well as for geometric movement or shape alteration. In this section we will modify the coil current excitation to make it a variable available for parametric analysis.

1. In the Excitations area of the Project Manager tree, double-click the **Current1** excitation to open the **Current Excitation** window.
2. Replace **10000** in the value field with the variable **curr** and click **OK**.
3. In the **Add Variable** dialog box, enter **10000 A** into the value and unit fields as shown below. Click **OK** to complete the variable assignment.

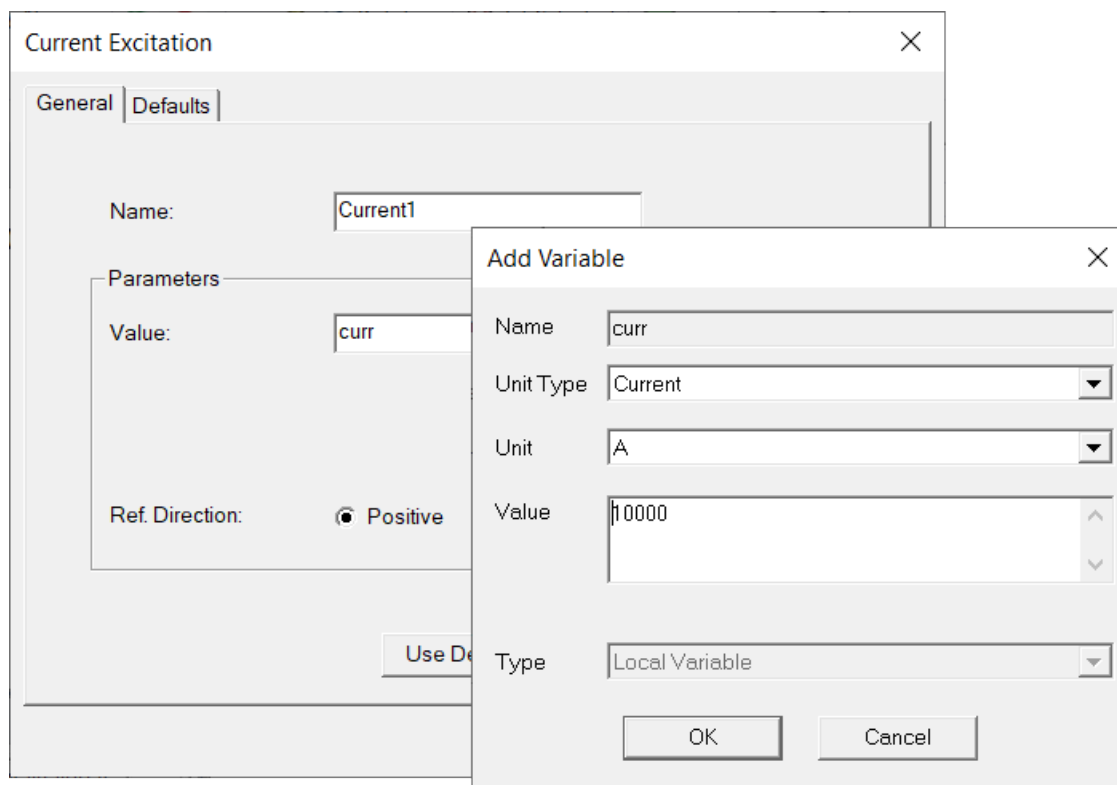

Set Variable Ranges for Parametric Analysis

Once variables have been added to the project, you must specify the range over which you want the variables to be varied in the analysis.

1. Begin by selecting **Maxwell 2D > Optimetrics Analysis > Add Parametric**. The Setup Sweep Analysis window is displayed.
2. In the **Sweep Definitions** tab, click **Add**. The Add/Edit Sweep window is displayed with a default variable selected.

- Verify that the variable is set to **deltagap** and **Linear Step** is selected as the sweep type. Enter the Start, Stop, and Step size information from the following table.

Value	Data
Start	0.000
Stop	0.500
Step	0.050

- After entering the data listed, click the **Add** button to transfer the sweep spec to the table on the right.
- Switch the selected Variable to **curr** and the sweep type to **Linear Count**. Complete the current sweep entry from the following table.

Value	Data
Start	0
Stop	1500
Count	11

- After entering the data listed, click the **Add** button to transfer the sweep spec to the table on the right.
- Verify that two sweep entries exist in the table on the right side of the window and click **OK**.

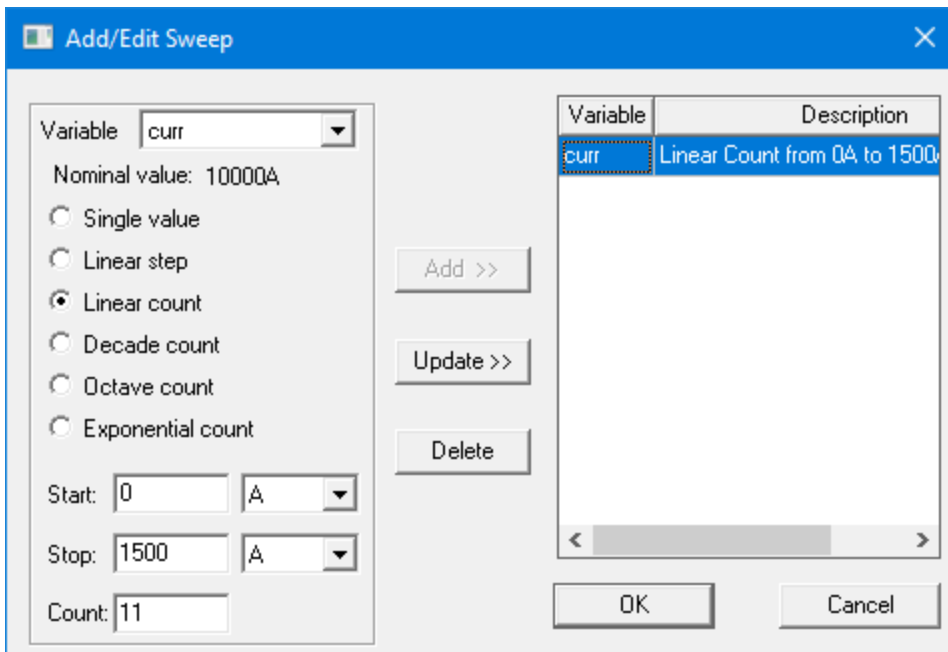

8. In the **Setup Sweep Analysis** window, select the **Options** tab and check **Copy geometrically equivalent meshes**. This will allow the simulator to reuse meshes for the coil current variations and save meshing time and overall analysis time.
9. Also in the **Options** tab, check **Save Fields and Mesh**.
10. Finally, select the **Calculations** tab. Click on the **Setup Calculations** button to display the **Add/Edit Calculation** window.
11. Select **Force** under Category in the **Trace** tab and click the **Add Calculation** button.
12. Select **L** under Category in the **Trace** tab and click the **Add Calculation** button.
13. Select **Done** to return to the Setup Sweep Analysis window, which should now contain two calculations to be performed during each parametric analysis step as shown below.

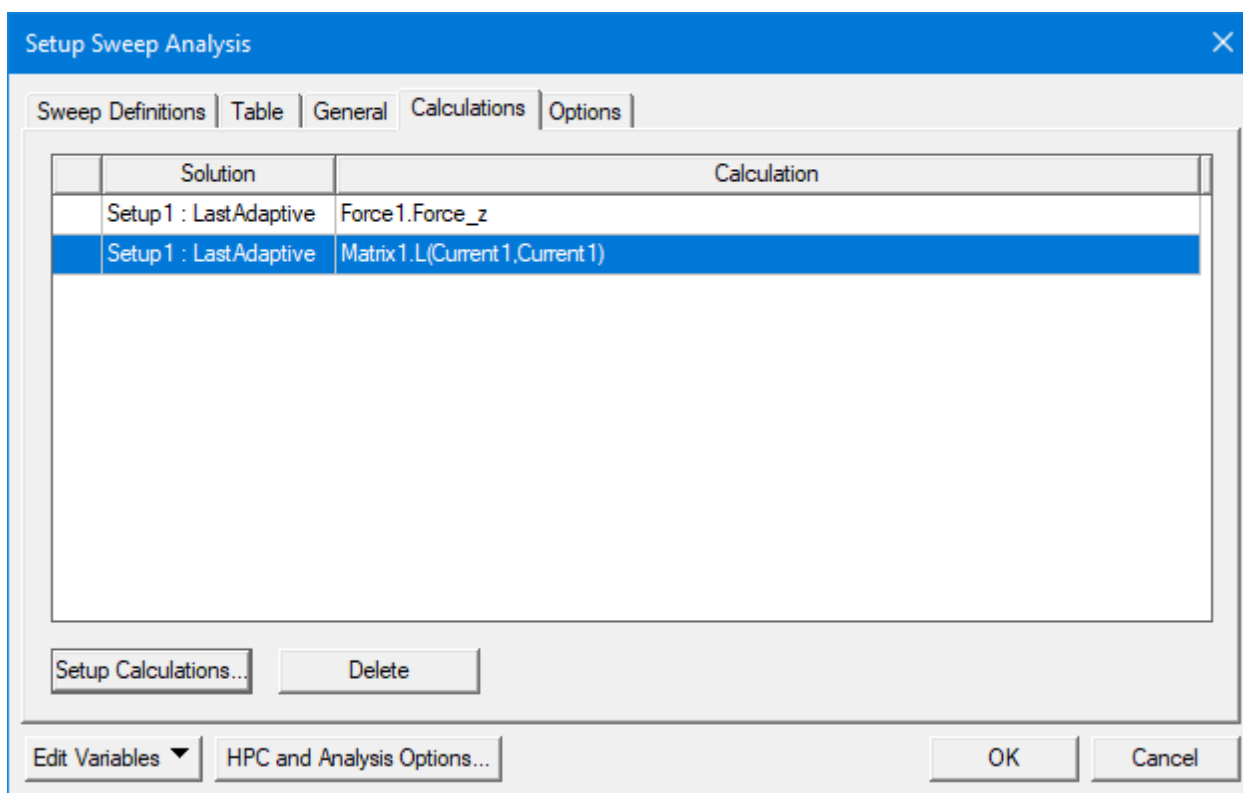

The basic parametric analysis setup is complete; however, it is instructive to note a few additional capabilities of the Setup Sweep Analysis before dismissing the window.

- The **Table** tab can be used to edit individual entries or to add or delete entire rows of the table.
- The **General** tab allows you to set the values for any variables the design may contain that you have chosen not to include in a sweep. In addition, you can select the solution process parameters by selecting a setup in the Sim Parameters area of the window.

- In the **Options** tab, you specify whether you want to save the Fields and Mesh for post processing purposes.
14. Click **OK** to dismiss the window.

Redefining Zero Current Sources

The variable spreadsheet is now filled. It has 121 entries (called setups) in it, one for each combination of the values of **deltagap** and **curr**. But you still have a little more work to do. You swept the **curr** variable starting at 0 amperes; however, it would be a waste of time to solve for a zero solution. In addition, because we want to re-use the mesh, we need to make sure that we start off with a solution that will provide good meshing overall. Therefore, you need to edit the spreadsheet and replace all the zeros in the **curr** column with -1 ampere.

To accomplish this, do the following:

1. In the Project Manager tree, double-click **ParametricSetup1** in the **Optimetrics** folder.
The **Setup Sweep Analysis** window appears.
2. Select the **Table** tab.
3. Scroll through the table and change each row containing **0A** for the variable **curr** to **-1A**.
4. Click **OK** to complete the changes.

Save Variables and Parameter Setup

Having added variables for both the geometric variation and the coil current; as well as, defining the sweep ranges for each, it is a good time to save the setup.

- Select **File > Save**.

The **Solenoid_param** geometry is saved and you are now ready to move on to the solution of the parametric model.

8 - Generating a Parametric Solution

Now that you have added physical constraints to the geometry and set up the parametric variable table, you are ready to generate a parametric solution for the solenoid model. You will do the following:

- Generate the magnetostatic solution for each variant on the original model.
- Compute the force on the core as a function of the core position and the current in the coil. (Because you requested force using the **Parameters** command, this automatically occurs during the parametric solution process.)
- Compute the inductance in the coil as a function of core position and the current in the coil. (Because you requested coil inductance using the **Parameters** command, this automatically occurs during the parametric solution process.)
- Review the **Convergence**, **Profile**, and **Force** results of the Parametric analysis.

Model Verification

You can quickly verify that the spreadsheet contains only valid geometric sweep parameters for the geometry. To verify the model:

1. Select **View/Animate**. The create animation setup window appears:

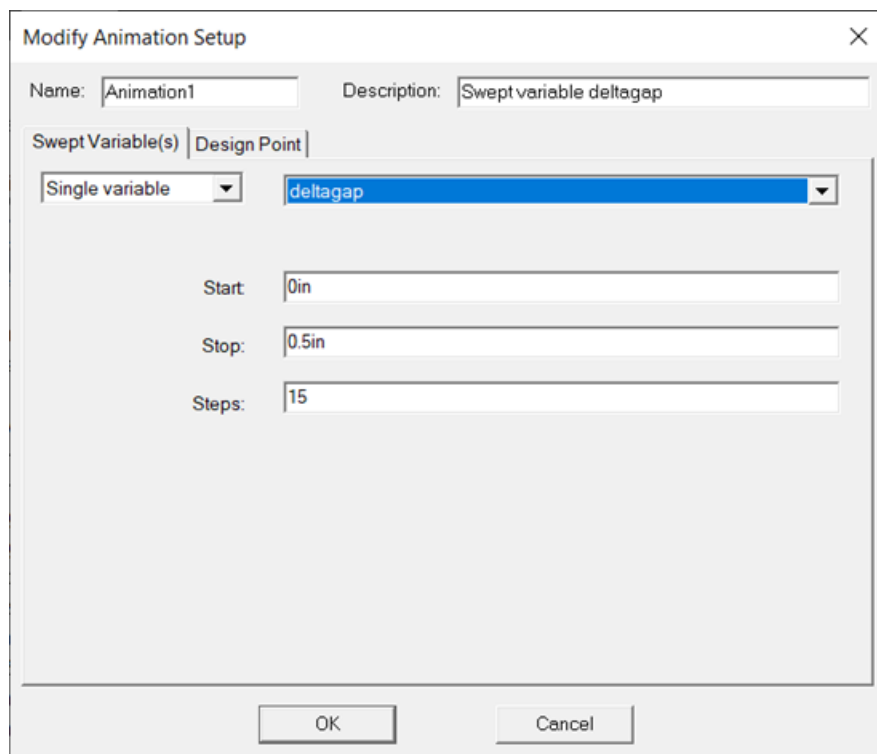

2. Enter **0in** for **Start**, **0.5in** for **Stop**, and **15** for the number of **Steps**. These values are consistent with the values used in the sweep setup.
3. Click **OK**.
4. The **Animation** dialog box is displayed. Click **Animate** and the modeler window shows the geometry animated with the motions of the **Core** object over the range of values for **deltagap**.

Note: Over the range of values used for **deltagap**, there is no geometry overlap.

5. Click **Close** in the Animation dialog box to end the model animation.

Solving the Nominal Problem

Now that you have examined the geometric parameters, the problem is ready to be solved. As a general practice, you should first solve the nominal problem to make sure that the problem is set up correctly. If the nominal problem solves properly, then the parametric solution should be sufficient.

To solve the nominal problem:

1. In the **Project Manager** tree, right-click **Setup1** under **Analysis** and select **Analyze**.
A solution is generated for the nominal values of the solenoid parameters.
2. Once the solution has completed, right-click **Setup1** under **Analysis** and select **Convergence** to view the results. If the solution progressed normally, you will see the number of **Triangles** increasing with each pass, and the **Energy Error** decreasing to less than 1%.

Solving the Parametric Problem

You have set up your parametric table with each row to be solved. Depending on your computer, each row will require a few minutes to solve. During the setup you selected **Copy Geometrically Equivalent Meshes** which will improve the solution time; however, you may want to start the solution when there is at least 10 to 15 minutes available for processing.

To start the parametric solution:

- Right-click **ParametricSetup1** under **Optimetrics** in the Project Manager tree and select **Analyze**.

The solution process begins.

Note: Do not be alarmed if the values you obtain for percent energy error, total energy, inductance, or force differ slightly from the ones given in this guide. The results that you obtain should be approximately the same as the ones given here.

Monitoring the Solution

When performing a parametric analysis, the dual monitoring bar shown below is displayed in the **Progress** window. The top bar displays the progress regarding the solutions in the analysis table. In this case, 120 total analyses are to be performed as a result of the variation of the **deltagap** and **curr** variables.

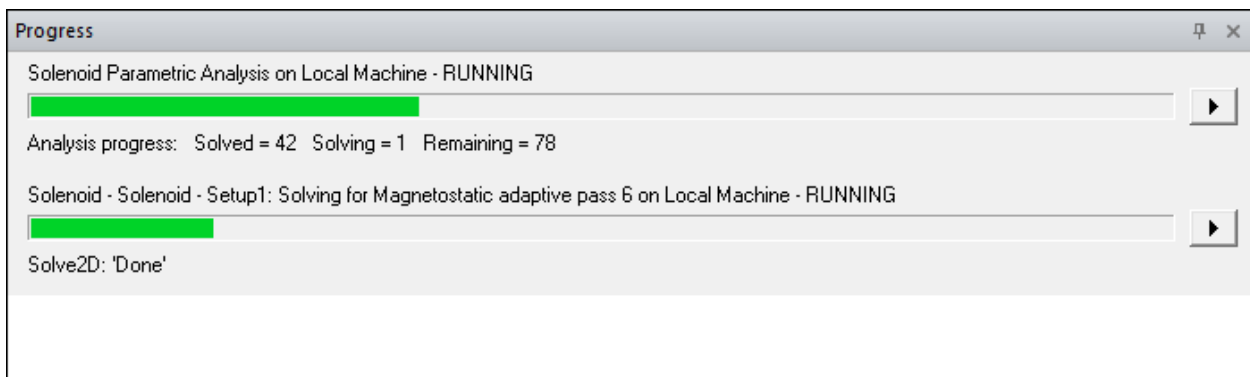

The bottom progress bar shows the standard progress in the solution of each individual row of the analysis table.

Viewing Parametric Solution Data

During the solution process, you may view solutions, the solution convergence, and the solution status or profile of any row in the table.

To view the parametric solution data during the solution process:

1. In the Project Manager tree, right-click **Results** and select **Solution Data** from the shortcut menu.

The **Solutions** window is displayed. By default, the design variation is set to the **Nominal** problem.

2. Click on the ellipsis button next to the design variation to display the **Set Design Variation** window as shown.

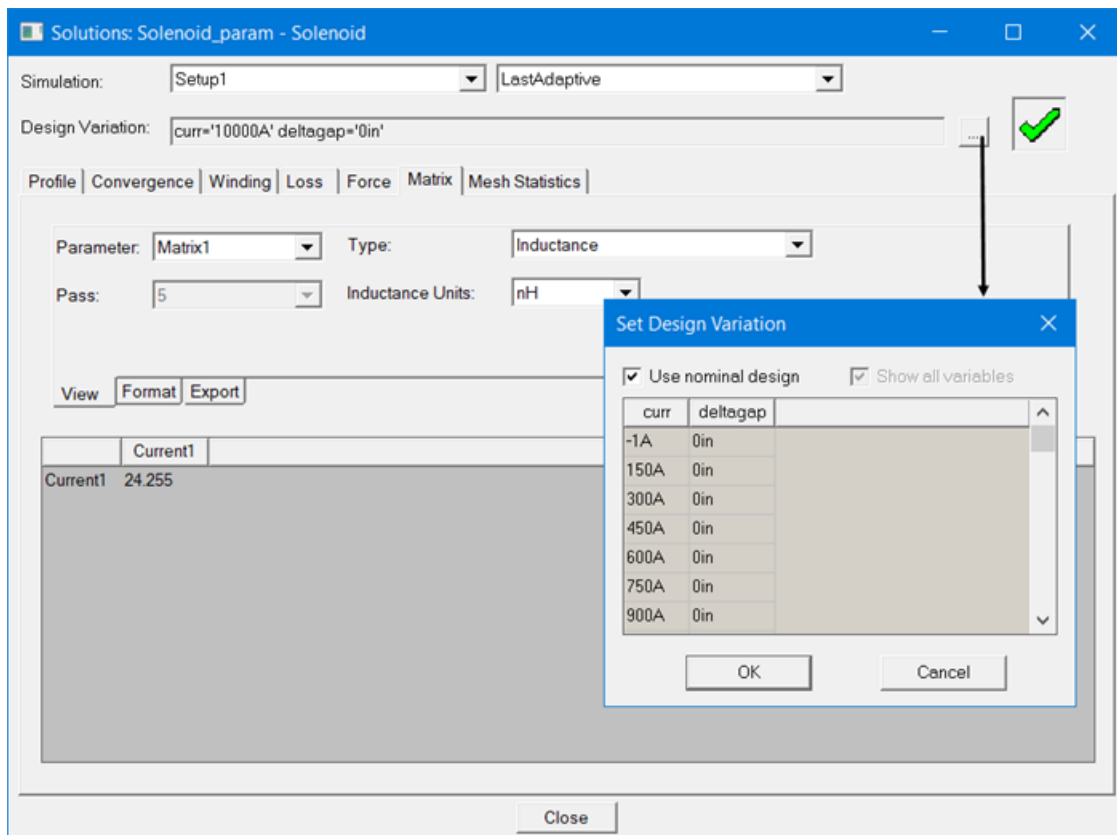

3. Uncheck the **Use nominal design** checkbox.
4. Select any row in the table by clicking to highlight it and click **OK**.
5. The design variation in the Solutions window now shows the profile, convergence information, force, *etc.* associated with the selected variable values.

Viewing Parametric Convergence Data

After selecting a design variation, select **Convergence** to monitor how the solution is progressing.

- For example, if you choose the variation corresponding to **Curr=-1A** and **deltagap=0.1in**, then click the **Convergence** tab, you will see something like what is shown below:

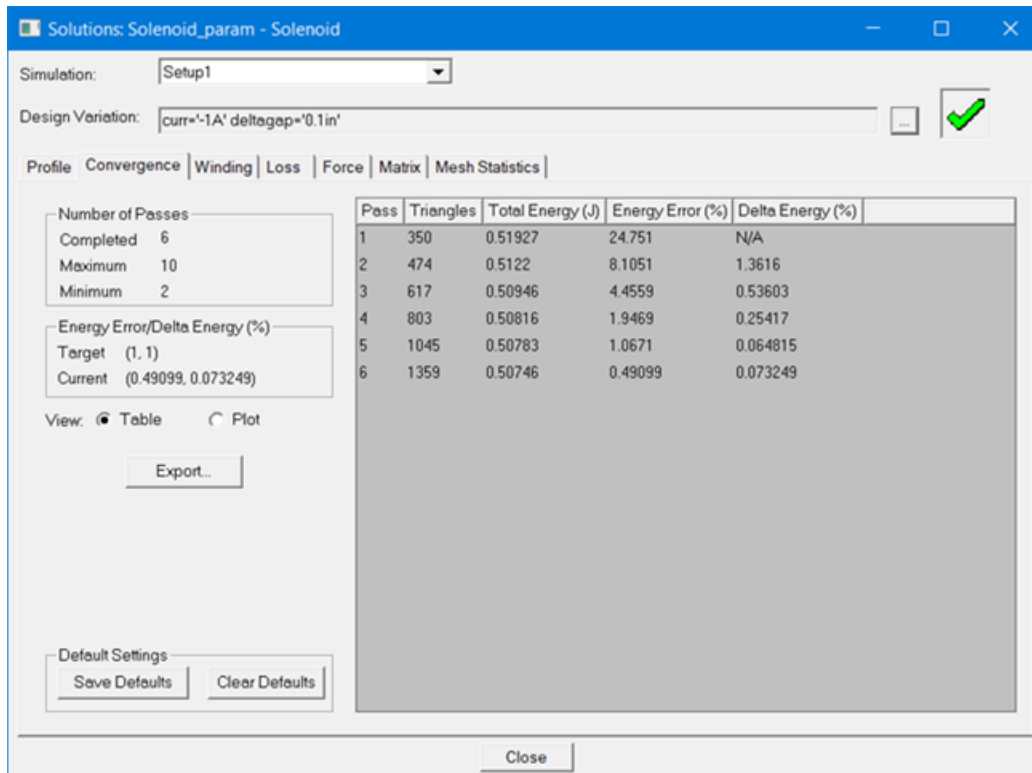

- The mesh has been iteratively increased as shown in the **Triangles** column, and the corresponding **Energy Error** has been decreased to less than 1%.
- You may change the View from **Table** to **Plot** by clicking the **Plot** radio button and selecting which quantities should be plotted on the **X** and **Y** axes.

Plotting Parametric Convergence Data

In addition to viewing the results for each design variation, you may view the results as a function of the design variable values.

1. In the Project Manager tree, right-click **ParametricSetup1** under the **Optimetrics** folder and select **View Analysis Result**.
2. Using the drop-down menu, select **deltagap** as the variable to plot on the X axis.
3. Select **1050A** for the variable **curr** and click **OK**.

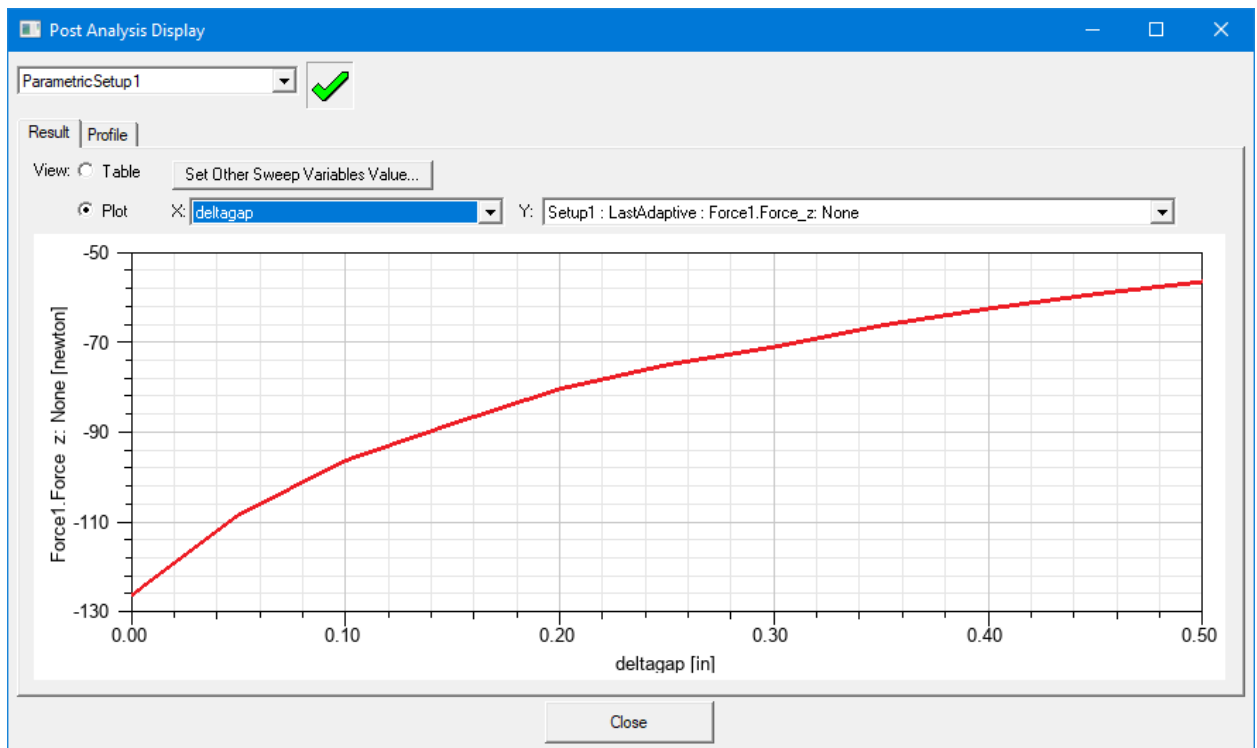

4. In order to review the Inductance of the coil, use the **Y axis** drop-down menu and select **L (Current1, Current1)**.

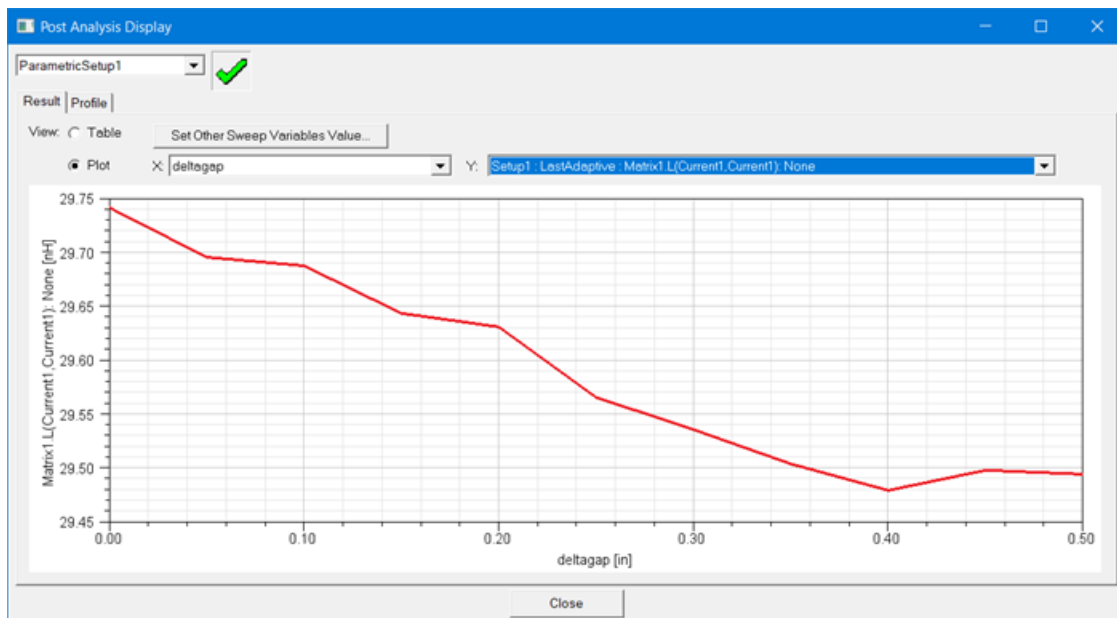

- You may inspect the performance at other values of **curr** by clicking the **Set Other Sweep Variables Value** button and selecting the value of interest.

Viewing Parametric Solver Profile

Individual design variations may be inspected to see the solver profile as well.

- In the **Post Analysis Display** window, select the **Profile** tab.

The following screen appears:

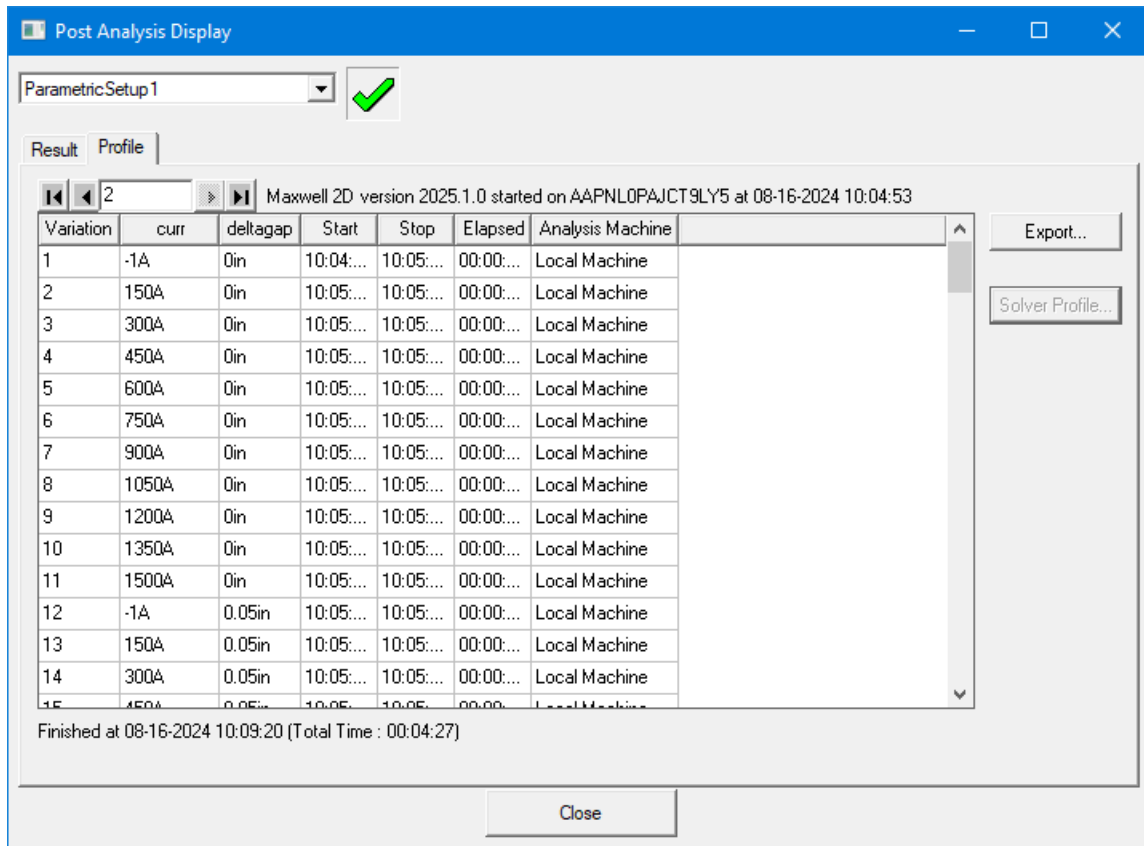

- The **Start**, **Stop** and **Elapsed** time for each variation is shown in the table. Select **Variation 8** by clicking on it in the table.
- Click the **Solver Profile** button.
- The **Solutions** window is displayed with the selected design variation loaded and the **Profile** tab selected.

The following information is displayed for each completed adaptive field solution and mesh refinement step. If more data is available than can fit on a single screen, scroll bars appear.

Task	Displays the system command that was used.
Real time	Displays the time taken to complete the step.
CPU time	Displays the time taken by the CPU to complete the step.
Memory	Displays the amount of memory used.
Information	Displays the number of triangles in the finite element mesh, size of the matrix, disk space used and other information relevant to the solution process.

5. Click **Close** to dismiss the **Solutions** window and return to the **Post Analysis Display** window.
6. Click **Close** to dismiss the **Post Analysis Display** window.

9 - Plotting Results from a Design Variation

With the result of design variations available, you can use the post processor to create reports and plot fields with multiple variations. In this section, you will do the following:

- Create a report of force vs. gap with multiple traces for each current level
- Set the Design Variation for plotting fields from a design variation
- Animate a field plot using the Design Variation values for the gap

Access Parametric Post Processor

You will use the post processor to plot the force on the core as a function of position for different values of coil current.

To access the postprocessor:

1. Select **Maxwell 2D > Results > Create Magnetostatic Report > Rectangular Plot**.

Alternatively, right-click on **Results** in the Project Manager tree, and select **Create Magnetostatic Report > Rectangular Plot** from the shortcut menu.

The **Report** window appears.

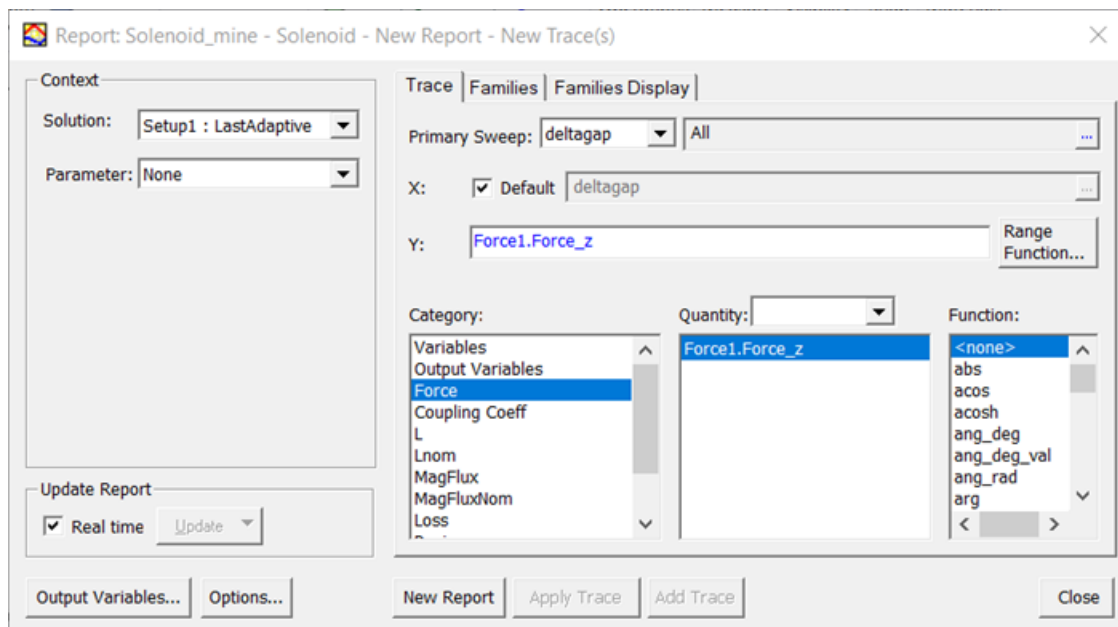

2. We want to plot force as a function of position, so make sure that the variable **deltagap** is selected as the **Primary Sweep** variable.
3. Also, make sure that **Force** is selected under the Category list.
4. Click on the **Families** tab to set the values of **curr** to plot.

- In the **Families** tab, you may select **Sweeps** or choose individual variations for the variable **curr** as shown.

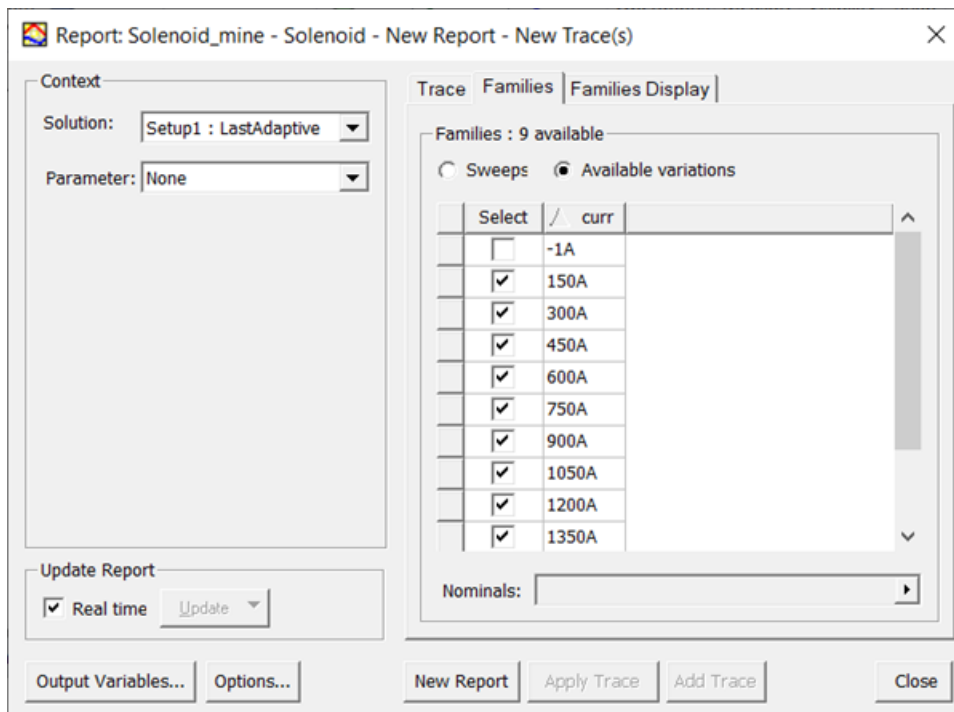

- Click **New Report** to plot the force versus gap spacing for various current values.
- Click **Close** to dismiss the **Report** window and view the family of curves as shown below.

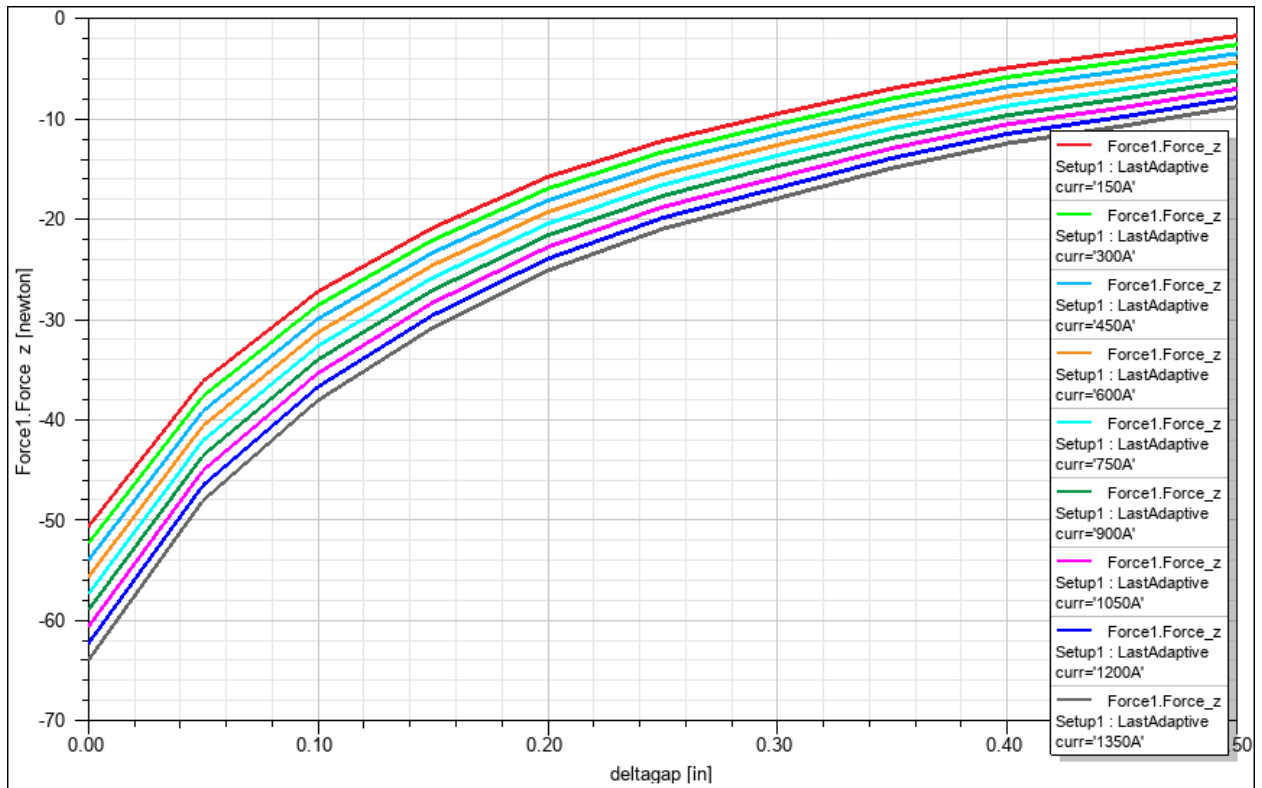

Plotting Fields of a Design Variation

In order to plot the fields from a particular design variation, you must have told the software to save the fields from the parametric analysis during the setup process. You did this in the "[Set Variable Ranges for Parametric Analysis](#)" on page 7-4 section of this guide.

To plot the fields from a particular design variation, you must first "[Apply Solved Variation](#)" below.

Apply Solved Variation

1. Tell the software which variation to use: select **Results > Apply Solved Variation** from the **Maxwell 2D** menu or the shortcut menu.

The **Set Design Variation** dialog box is displayed as shown.

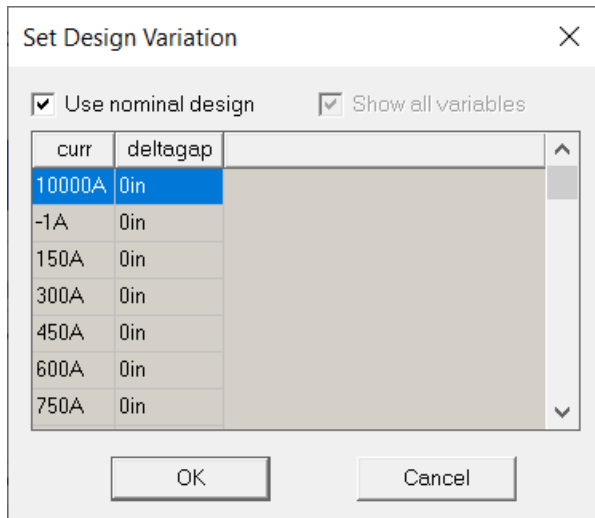

2. Uncheck the **Use nominal design** option.
3. Scroll to the **curr=1500A, deltagap=0.5in** line and highlight it by clicking on it.
4. Click **OK** to make it the new “Nominal Design” and be able to plot fields.

Note: The model view changes as the design variation is applied.

Plot Fields for the Variation

To plot the magnetic field for the variation:

1. Click **Edit > Select All** in the menu, or click in the modeler window and press Ctrl+A. All objects in the model will be highlighted.
2. Click **Maxwell 2D > Fields > Fields > H > Mag_H**.

The **Create Field Plot** window appears.

3. Click **Done** to accept the plot definition and create the field plot similar to the one shown below.

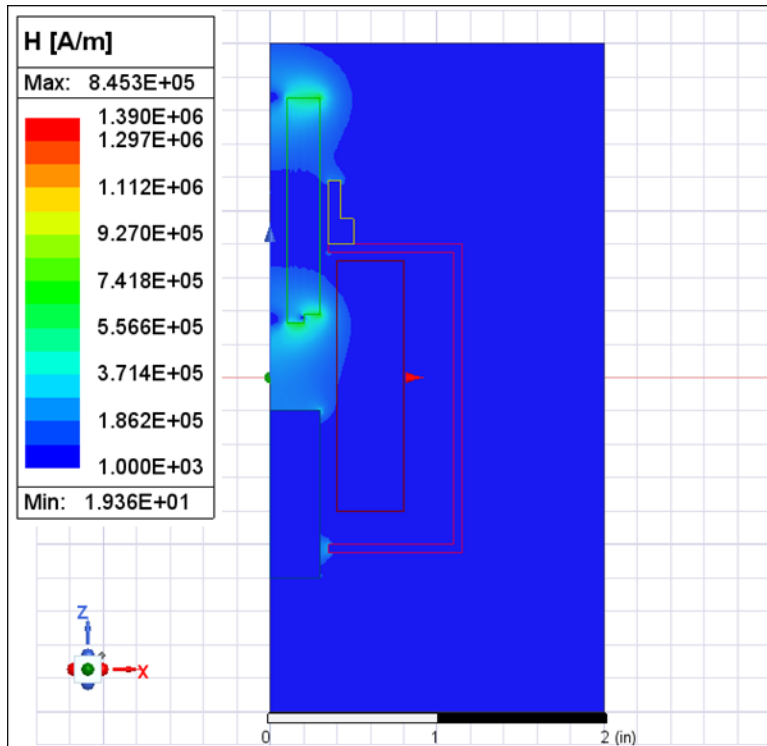

4. Right-click on the plot **Key** and select **Modify** from the shortcut menu.
5. Click on the **Scale** tab.
6. Because the field plot is dominated by the field in the core, click on the **Log** radio button to see more field pattern in the low field regions. Make sure **Auto** is selected for the limits.

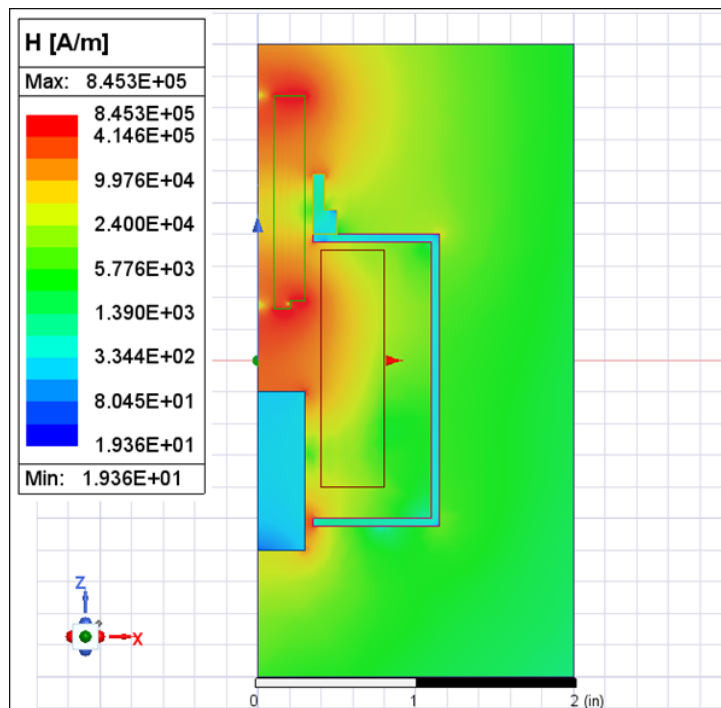

7. Click **Close** to dismiss the window.

Animate the Field Plot Across Variations

In order to see how the field changes with the size of the gap you can animate the field as follows:

1. In the Project Manager tree, right-click on **Field Overlays**, and select **Animate**.
2. The **Setup Animation** window appears.

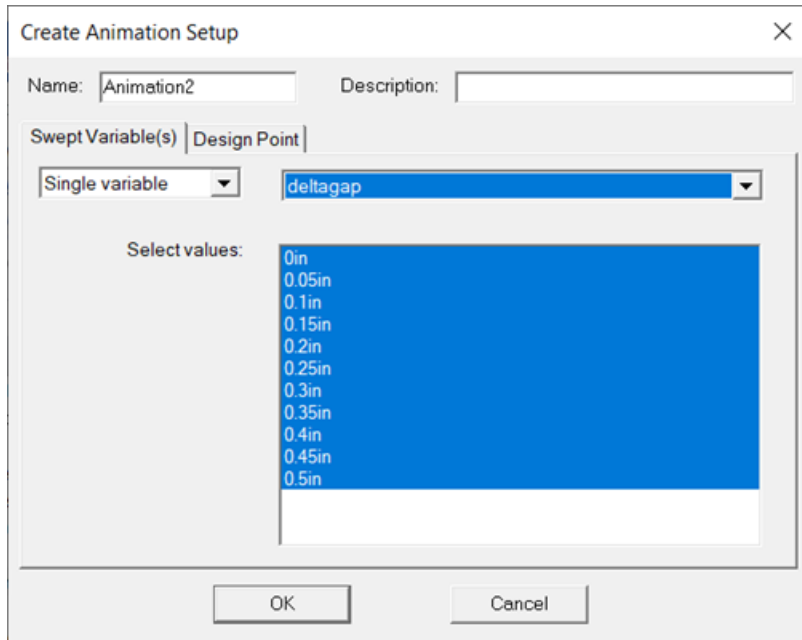

3. All values for **deltagap** are selected by default. Click **OK** to accept, then click **Animate** to view the field plot.
4. Click **Export** to save the animation as a .gif or .avi file.
5. Click **Close** in the **Animation** window.

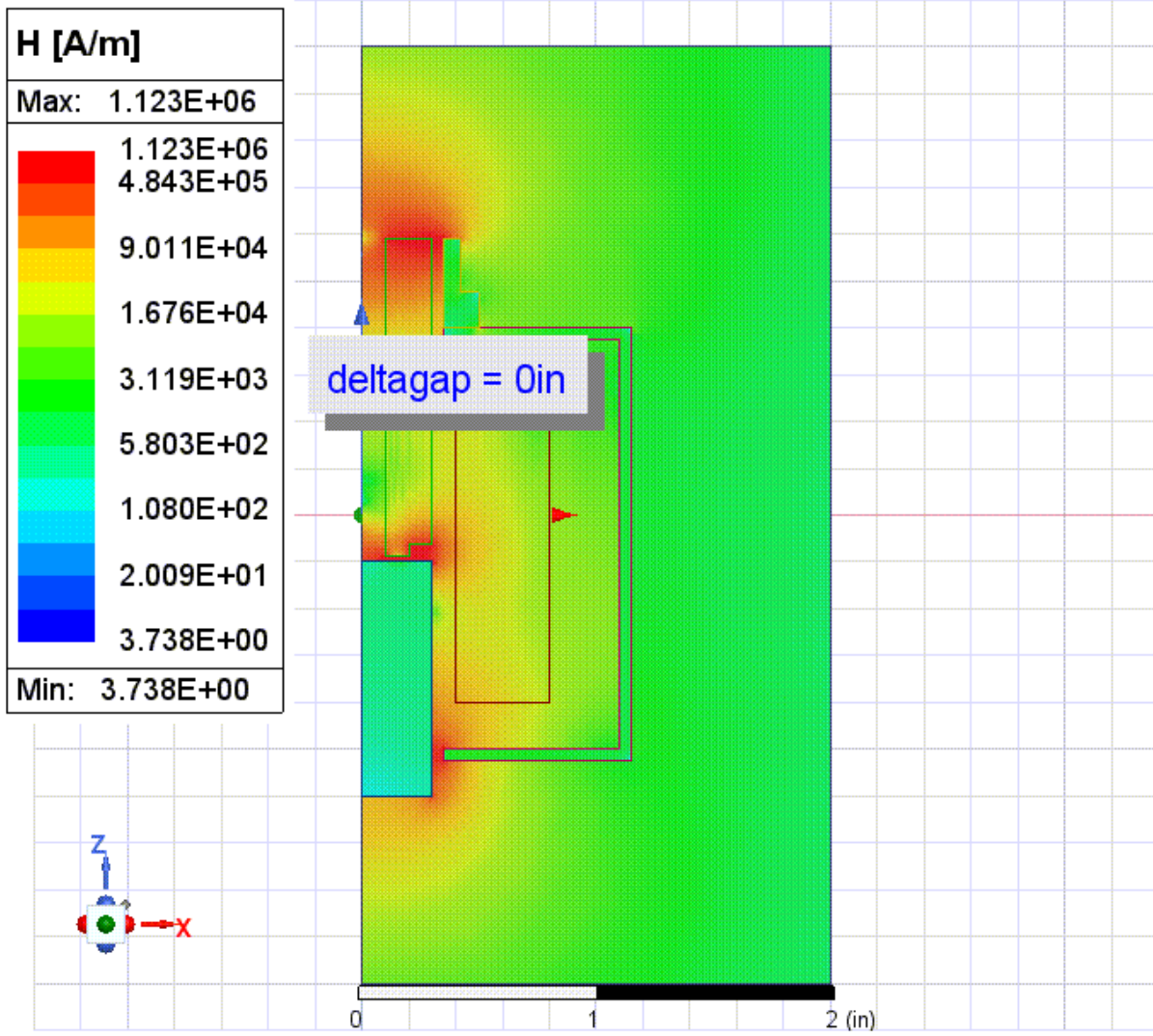

10 - Exit the Electronics Desktop

You have successfully completed the 2D Magnetostatic Solenoid Getting Started Problem.

1. Save the project plots and reports by clicking **File > Save**. Ansys Electronics Desktop will save all data including the plots you have created for later use.
2. To exit the Ansys Electronics Desktop software, click **File > Exit**.

Index

A

adaptive analysis 5-2
air space 7-1
animating the parametric model 8-1
attributes
 color 3-3
 name 3-3
axisymmetric models 1-3

B

B-H curve
 adding points to 4-4
 defining 4-4 , 4-11
 fitting curve to points 4-4
 for cold rolled steel 4-4
 for SS430 4-11
 keyboard entry 4-4
background
 and boundary conditions 4-13
 ballooning 4-15
 default material for 4-13
 extending 4-15

 including in solution region 4-12
background region 3-7
balloon boundary, definition of 4-14
bonnet, assigning a material to 4-3
boundary conditions 4-13
 balloon 4-14
 for sample problem 4-14
 use of 4-13

C

coil
 assigning a material to 4-2
 assigning source current to 4-14
cold rolled steel
 defining as a material 4-3
 entering B-H curve for 4-3
computing resources
 clock time 5-9 , 8-7
 commands executed 5-9
 CPU time 5-10 , 8-8
 memory size 5-9 , 8-7
 number of elements 5-9 , 8-7
 viewing 5-9
Convergence 5-7

- convergence data
 - delta energy 5-7 , 5-8
 - energy error 5-7 , 5-8
 - mesh size 5-8
 - number of passes 5-8
 - pass number 5-8
 - plotting 5-8
 - target error 5-7
 - total energy 5-8
 - viewing 5-7 , 5-8
 - core, assigning a material to 4-10
 - creating the background region 3-7
 - current, assigning to coil 4-14
- D**
- defining the background region 3-7
 - delta 5-8
 - dimensions of geometric constraints 7-1
 - drawing
 - line 3-3
 - rectangle 3-3
 - drawing units 2-2
- E**
- editing spreadsheet variables 7-7
 - energy 5-8
 - error 5-2 , 5-7 , 5-8
- total 5-8
 - error
 - energy 5-7 , 5-8
 - of solution 5-2
- F**
- force
 - and solution process 4-17
 - components of 6-1
 - computing for the solenoid core 4-17
 - direction of 6-1
 - magnitude of 6-1
 - viewing solution results 6-1
- G**
- gap, defining 7-1
 - generating a solution 5-1
 - geometric models, axisymmetric 1-3
 - geometry layout 3-1
- I**
- inductance
 - and solution process 4-17
 - computing for the coil 4-17
- K**
- keyboard entry 3-3
 - keyboard, selecting points with 4-4

M

magnetic coercivity 4-7

magnetic field, solving for 5-4 , 8-1

magnetic retentivity 4-7

magnetization

- relationship to other properties 4-7
- specifying direction of 4-9

magnetostatic solution type 2-2

manual coordinate entry 3-2

material database 4-1

- adding materials to 4-1

Material, Add 4-3

materials

- adding to local database 4-1
- assigning to objects 4-1
- assigning to the background 4-12
- assigning to the bonnet 4-3
- assigning to the coil 4-2
- assigning to the core 4-10
- assigning to the plugnut 4-10
- assigning to the yoke 4-3
- nonlinear 4-3 , 4-11
- permanent magnets 4-6

Maxwell

- renaming a design 2-1

- renaming a project 2-1

Maxwell Field Simulator, exiting 9-6 , 10-1

memory used during solution 5-9 , 8-7

mesh

- example of 1-1
- initial 5-5
- number of triangles in 5-8
- use of 1-1

mesh refinement

- adaptive 5-2
- and error energy 5-2
- percentage refined 5-2

message bar, during solution process 8-3

N

Neo35

- creating 4-6
- specifying direction of permanent magnetization 4-9
- specifying properties of 4-8

nominal model, generating a solution for 5-4 , 8-1

nonlinear materials

- adding 4-3 , 4-11
- defining B-H curve for 4-3 , 4-11

O

objects
 assigning materials to 4-1
 selecting 4-11
opening a project 2-1

P

parametric convergence, plotting 8-5
parametric model
 generating a solution for 8-1
 post processing 9-1
parametric profile, viewing 8-7
permanent magnets
 creating 4-6
 direction of magnetization in 4-9
plots, convergence data 5-8
plugnut, assigning a material to 4-10
points, entering from the keyboard 4-4
Post Process/Variables 9-1
post processing 9-1
Profile 5-9
projects, opening and saving 2-1
properties window 3-3

R

rectangle, drawing 3-2
relative permeability 4-7
renaming
 a design 2-1
 a project 2-1
residual 5-3

S

saving a project 2-1
scientific notation, ANSYS' 4-4
scroll bars 5-10
set up boundaries/sources 4-13
setting drawing units 2-2
setup materials 4-1
size
 of finite element mesh 5-8 , 5-9 , 8-7
 of memory during solution 5-9 , 8-7
solenoid
 behavior being modeled 7-1
 geometric constraints on 7-1
solution type 2-2
solutions
 adaptive analysis of 5-2
 and adaptive mesh refinement 5-2
 calculated values 5-1 , 5-3

computing 5-4 , 8-1

convergence 5-7

criteria for computing 5-1 , 5-3

force 6-1 , 6-1

interpolated values 5-1 , 5-3

interrupting 5-8

monitoring 8-3

refinement of 5-2

satisfying equations 5-3

total energy 5-8

viewing fields 6-1 , 7-1 , 9-1

viewing profile data for 5-9

viewing results 8-1

Solve 5-5

Nominal Problem 8-2

solver residual 5-3

sources 4-13 , 4-13

for sample problem 4-14

SS430

defining as a material 4-10

entering B-H curve for 4-11

T

triangles, number in mesh 5-8 , 5-9 ,
8-7

V

variables spreadsheet, editing 7-7

Variables/Animate 8-1

Y

yoke, assigning a material to 4-3

Z

zero sources, redefining 7-7